



Better things for better living

SORVALL[®]
RC-5B PLUS

Service Manual

PRELIMINARY

NOTE

***This manual contains preliminary information
for the RC-5B PLUS centrifuge only.***

SERVICE MANUAL

SORVALL[®] RC-5B PLUS ***Refrigerated Superspeed Centrifuge***

Du Pont Company
SORVALL[®] Products
Wilmington, Delaware 19898
U.S.A.

SORVALL[®] Centrifuges



PRELIMINARY
Issued June 1993

This manual is a guide to the service of the

SORVALL® RC-5B PLUS Superspeed Centrifuge

Data herein has been verified and validated and is believed adequate for the intended use of the instrument. Because failure to follow the recommendations set forth in this manual could produce personal injury or property damage, always follow the recommendations set forth herein. DuPont does not guarantee results and assumes no obligation for the performance of products that are not used in accordance with the instructions provided. This publication is not a license to operate under, nor a recommendation to infringe upon any process patents.

This service manual is intended for use only by qualified service personnel. Due to the high electrical potential in these instruments, untrained personnel must not attempt any of the procedures contained in this service manual.

This service manual is intended as a service aid. While the manual is kept current and includes information regarding significant design changes, specific designs may still vary from instrument to instrument.

WARNING, CAUTION, and NOTE within the text of this manual are used to emphasize important and critical instructions.

WARNING informs the operator of a hazard or an unsafe practice that could result in personal injury, affect the operator's health, or contaminate the environment.

CAUTION informs the operator of an unsafe practice that could result in damage of equipment.

NOTE highlights essential information.

CAUTION and **WARNING** are accompanied by a hazard symbol  and appear in the left sidebar near the information they correspond to.

Important Safety Information

Certain potentially dangerous conditions are inherent to the use of all centrifuges. To ensure safe operation of this centrifuge, anyone using it should be aware of all safe practices and take all precautions described below and throughout this manual.



W A R N I N G

When using radioactive, toxic, or pathogenic materials, be aware of all characteristics of the materials and the hazards associated with them in the event leakage occurs during centrifugation. In the event of a rotor failure, neither the centrifuge nor the rotor can protect you from particles dispersed in the air. To protect yourself, we recommend additional precautions be taken to prevent exposure to these materials, for example, use of controlled ventilation or isolation areas.

Always be aware of the possibility of contamination when using radioactive, toxic, or pathogenic materials. Take all necessary precautions and use appropriate decontamination procedures if exposure occurs.

Never use any material capable of producing flammable or explosive vapors.

Never exceed the maximum rated speed of the installed rotor; to do so can cause rotor failure.

Table of Contents

	<i>Page</i>
Disclaimer	ii
 Section 1. INTRODUCTION & DESCRIPTION	
1-1. Intended Use	1-1
1-2. Centrifuge Description	1-1
1-3. Centrifuge Accessories	1-2
1-4. Centrifuge Warranty	1-3
1-5. Service Decontamination Policy	1-3
 Section 2. INSTALLATION	
2-1. Inspection	2-1
2-2. Location Requirements	2-1
2-3. Electrical Requirements	2-1
2-4. Installation	2-2
2-5. Rewiring the Centrifuge	2-3
Conversion to Single-Phase Permanent Wiring	2-3
2-6. Test Run Procedure	2-4
 Section 3. OPERATION	
3-1. Setting Centrifuge Power On	3-1
3-2. Opening the Chamber Door	3-1
3-3. Centrifuge Controls Description	3-1
3-4. Centrifuge Operation	3-3
3-5. Rotor Speed/Temperature Differential Compensation	3-4
3-6. Precautions to Prevent Samples from Freezing	3-5
3-7. Rotor Precool	3-7
3-8. Troubleshooting	3-8
3-9. Reducing Speeds for Loads in Excess of Design Mass	3-9
 Section 4. SPECIFICATIONS	
4-1. Centrifuge Specifications	4-1
Rotor Information Table	4-3
 Section 5. PRINTED CIRCUIT BOARDS & SCHEMATIC DIAGRAMS	

Page

Section 6. CALIBRATION

6-1. Precautions for Handling Printed Circuit Boards	6-1
6-2. Calibration Sequence	6-2
6-3. Calibration Criteria and Adjustment Locations	6-2
6-4. Test Equipment Required	6-2
6-5. Calibration Procedures	6-2

Section 7. ILLUSTRATED PARTS**Section 8. PREVENTIVE MAINTENANCE**

NOT YET AVAILABLE

Section 9. REPAIR & REPLACEMENT

NOT YET AVAILABLE

Section 10. SYSTEM DESCRIPTIONS

NOT YET AVAILABLE

Section 11. TROUBLESHOOTING

11-1. Emergency Sample Recovery	11-1
11-2. General Troubleshooting (NOT YET AVAILABLE)	11-2

Tables

	<i>Page</i>
3-1. Centrifuge Controls	3-2
3-2. Troubleshooting	3-8
5-1. Component Description, Controller Printed Circuit Board	5-15
5-2. Component Description, Lower Control Printed Circuit Board	5-25
6-1. Calibration Sequence	6-5
6-2. Imbalance Detection Threshold	6-11
6-3. Test Point Descriptions for Controller P.C. Board, PN 74095 12987	6-14
6-4. Potentiometer Adjustment for Controller P.C. Board, PN 74095 12987	6-15
7-1. RC-5B PLUS Assembly, Front View	7-3
7-2. RC-5B PLUS Assembly, Right View	7-5
7-3. RC-5B PLUS Assembly, Rear View	7-7
7-4. RC-5B PLUS Panel Assembly, Main Breaker	7-8
7-5. RC-5B PLUS Front Console Panel Assembly	7-9
7-6. RC-5B PLUS Evaporator Assembly	7-11
7-7. RC-5B PLUS Drive Assembly	7-13
7-8. RC-5B PLUS Motor Assembly	7-15
7-9. RC-5B PLUS Door Interlock Assembly, Part A	7-17
7-10. RC-5B PLUS Door Interlock Assembly, Part B	7-19
7-11. RC-5B PLUS Constant Current Brake Assembly	7-21

Illustrations

	<i>Page</i>
1-1. Centrifuge Parts Location and Identification	1-2
2-1. Single-Phase Permanent Wiring	2-4
3-1. RC-5B PLUS Control Panel	3-3
5-1. System Diagram	5-3
5-2. Schematic for Controller P.C. Board Assembly, PN 74095 (4 sheets) ...	5-5 12987
5-3. Component Location: Controller Printed Circuit Board	5-13
5-4. Schematic for Lower Control Printed Circuit Board, PN 74089, 74306 ..	5-21
5-5. Component Location: Lower Control Printed Circuit Board	5-23
6-1. Test Point and Adjustment Locations for Controller P.C. Board Assembly, PN 74095 . 12987	6-4
6-2. Test Set-Up for Temperature Meter Deflection Adjustment	6-7
7-1. RC-5B PLUS Assembly, Front View	7-2
7-2. RC-5B PLUS Assembly, Right View	7-4
7-3. RC-5B PLUS Assembly, Rear View	7-6
7-4. RC-5B PLUS Panel Assembly, Main Breaker	7-8
7-5. RC-5B PLUS Front Console Panel Assembly	7-9
7-6. RC-5B PLUS Evaporator Assembly	7-10
7-7. RC-5B PLUS Drive Assembly	7-12
7-8. RC-5B PLUS Motor Assembly	7-14
7-9. RC-5B PLUS Door Interlock Assembly, Part A	7-16
7-10. RC-5B PLUS Door Interlock Assembly, Part B	7-19
7-11. RC-5B PLUS Constant Current Brake Assembly	7-20
11-1. Emergency Sample Recovery	11-1

Section 1: INTRODUCTION & DESCRIPTION

This manual is a service guide for the SORVALL[®] RC-5B PLUS Superspeed Refrigerated Centrifuge. It contains descriptive information, mechanical and electrical theories of operation, maintenance procedures, calibrations, and an illustrated parts list for ordering replacements.

1-1. Intended Use



WARNING

To avoid personal injury, all replacement and calibration procedures should be performed by qualified service personnel.

This manual is for qualified service personnel who are familiar with electronics and factory methods for performing repairs, adjustments, and calibrations. It provides a fault isolation method that isolates and identifies the cause of a problem within the centrifuge, a parts list, and information for ordering replacement parts needed for the repair of parts or systems within the centrifuge.

Warnings, Cautions, and Notes are used throughout this manual to emphasize important and critical instructions. Service personnel are expected to be familiar with their meaning (see page ii) and to read them before servicing the centrifuge.

1-2. Centrifuge Description

The RC-5B PLUS is a high-speed (to 21 000 rpm), floor-model centrifuge used to separate substances of different densities at controlled temperatures. Its function is to increase the effects of gravity by centrifugal force to separate substances of different size or densities at controlled temperatures.

The centrifuge has a fan-cooled motor that is balanced and enclosed in an air-cooled silencer to ensure smooth, quiet operation over its full speed range and to promote long life for the brushes and bearings. The durable motor brushes have increased life and the gyro-action self-centering drive spindle allows you to balance the centrifuge tubes by "eye" rather than by weighing them.

The refrigeration system is a low-temperature, hermetically-sealed unit consisting of a compressor, condenser, evaporator/rotor chamber and interconnecting tubing. It is charged with SUVA[™] refrigerant, one of DuPont's CFC-replacement coolants. During operation, the cooling system will maintain rotor compartment temperature within 1°C of setpoint.

Run parameters are selected by setting the dials on the front control panel. Actual run conditions are continuously displayed during operation by easy-to-read analog displays.

The RC-5B PLUS accepts the SORVALL® superspeed rotors listed in the Rotor Information Table in Section 4, which includes all the rotors compatible with earlier floor-model, superspeed centrifuges.

Refer to figure 1-1 to identify the parts of the RC-5B PLUS.

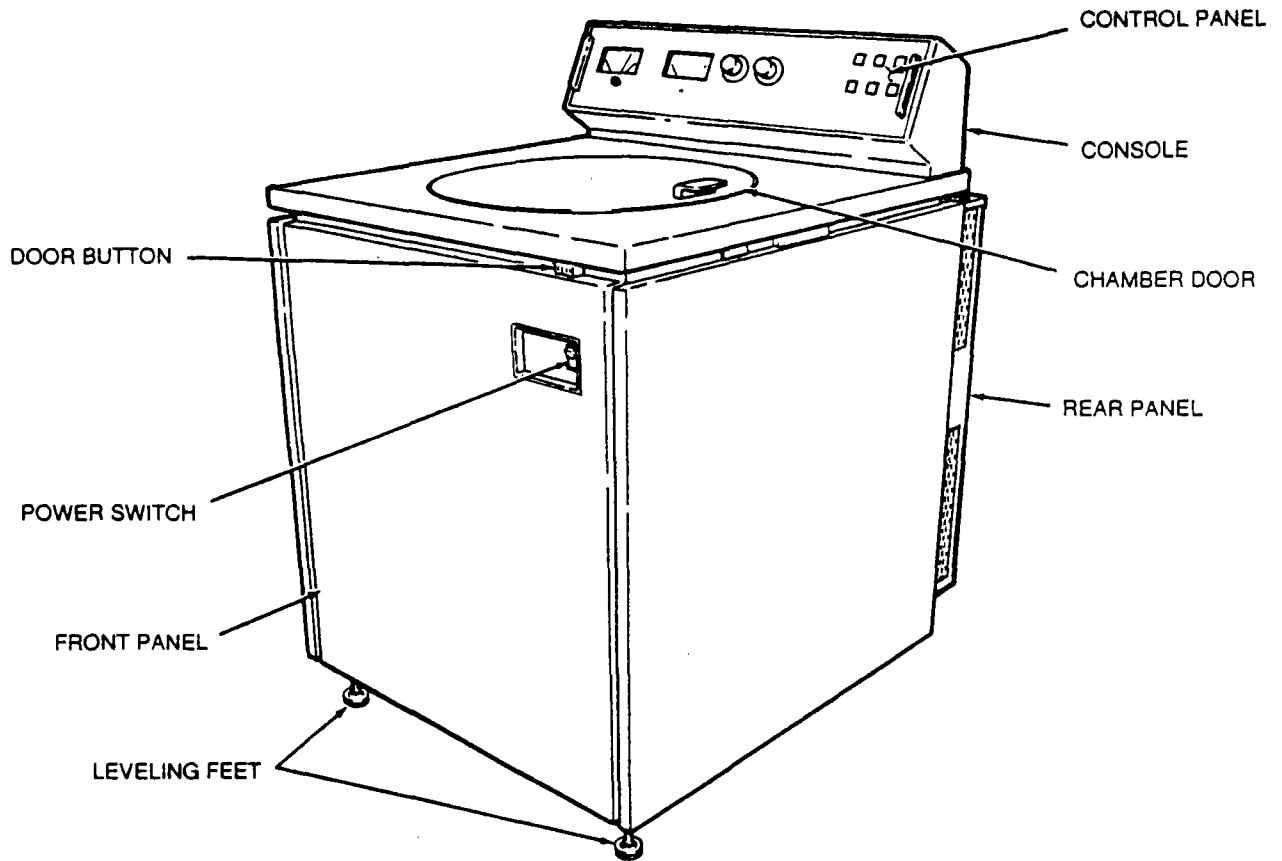

Figure 1-1. Centrifuge Parts Location and Identification

1-3. Centrifuge Accessories

The following accessories are provided with the centrifuge:

Catalog No.	Description
74143	Condensed Operating Instructions
74013	Instruction Manual
68025	9/16-inch Wrench
12284	Motor Brush Replacement Kit

1-4. Centrifuge Warranty

E. I. duPont de Nemours and Company makes no warranty of any kind, expressed or implied, except as stated in this warranty policy.

The SORVALL® RC-5B PLUS Superspeed Centrifuge is warranted to be free from defects in material and workmanship for a period of one year from the date of delivery. The compressor, condenser, evaporator and all interconnecting tubing are warranted to be free of defects in material and workmanship for a period of five years from the date of delivery. DuPont will repair or replace and return free of charge any part which is returned to its factory within said period, transportation prepaid by user, and which is found upon inspection to have been defective in materials or workmanship. This warranty does not apply to any damage to any instrument resulting from: normal wear and tear; misuse; abuse; use of electrical currents or circuits other than those specified on the plate affixed to the instrument; accident; negligence; failure to follow operating instructions; or use of any rotor other than a SORVALL™ rotor intended for use in this instrument.

DuPont reserves the right to change, alter, modify, or improve any of its instruments without any obligation whatsoever to make corresponding changes to any instrument previously sold or shipped.

The foregoing obligations are in lieu of all other obligations and liabilities including negligence and all warranties, of merchantability or otherwise, expressed or implied in fact or by law, and state our entire and exclusive liability and buyer's exclusive remedy for any claim or damages in connection with the sale or furnishing of goods or parts, their design, suitability for use, installation or operation. DuPont will in no event be liable for any special or consequential damages whatsoever, and our liability under no circumstances will exceed the contract price for the goods for which liability is claimed.

1-5. Service Decontamination Policy



WARNING

Because of the characteristics of the samples likely to be processed in this centrifuge, biological or radioactive contamination may occur. Always be aware of this possibility, and take normal precautions. Use appropriate decontamination procedures should exposure occur.

If a centrifuge or rotor that has been used with radioactive or pathogenic material requires servicing by DuPont personnel, either at the customer's laboratory or at a DuPont facility, comply with the following procedure to ensure the safety of all personnel:

1. Clean the centrifuge or rotor to be serviced of all encrusted material and decontaminate it (see "Cleaning and Decontamination" on page 4-2 of the RC-5B PLUS Operator Manual) prior to servicing by the DuPont representative or

returning it to the DuPont facility. There must be no radioactivity detectable by survey equipment.

The SORVALL[®] Rotors, Tubes, Bottles, Adapters, and Accessories Catalog contains descriptions of commonly used decontamination methods and a chart showing method compatibility with various materials. Also, this instruction manual contains specific guidance about cleaning and decontamination methods appropriate for the product it describes.

Clean and decontaminate your centrifuge and rotor as follows:

For rotors:

Remove tubes, bottles, and adapters from the rotor and decontaminate rotor using an appropriate method. If tubes or rotor caps are stuck in the rotor, or the rotor cover is stuck, notify DuPont representative; be prepared with the name and nature of the sample so the DuPont Chemical Hazards Officer can decide whether to authorize the rotor's return to a DuPont facility.

For superspeed centrifuges:

1. Remove rotor from the rotor chamber.
 2. Decontaminate chamber door, rotor chamber, and drive spindle using appropriate method (see "Cleaning and Decontamination" on page 4-2 of the RC-5B PLUS Operator Manual).
 3. Remove all encrusted material from around the motor and drive assemblies.
 4. Remove, wash, and decontaminate the motor sealing gasket and pad.
2. Complete and attach Decontamination Information Certificate (SORVALL[®] Instruments Form No. IPDP-59 or E53603) to the centrifuge or rotor before servicing or return to DuPont facility. If Certificate is not available, attach a written statement verifying decontamination (what was contaminant and what decontamination method was used).

If the centrifuge or rotor must be returned to a DuPont facility:

1. Contact your DuPont representative to obtain a Return Service Order Number (RSO No.); be prepared with the name and serial number of the centrifuge or rotor and the repairs required.
2. Send item(s) with the RSO No. clearly marked on the outside of packaging to the address obtained from your DuPont representative.

NOTE United States federal regulations require that parts and instruments *must* be decontaminated before being transported. Outside the United States, check local regulations.

If a centrifuge or rotor to be serviced does not have a Decontamination Information Certificate attached and, in DuPont's opinion presents a potential radioactive or biological hazard, the DuPont representative will not service the equipment until proper decontamination and certification is complete. If DuPont receives a centrifuge or rotor at its Service facilities which, in its opinion, is a radioactive or biological hazard, the sender will be contacted for instructions as to disposition of the equipment. Disposition costs will be borne by the sender.

Decontamination Information Certificates are included with these instructions. Additional certificates are available from the local Account Representative or Field Service Engineer. In the event these certificates are not available, a written statement certifying that the unit has been properly decontaminated and outlining the procedures used will be acceptable.

NOTE The Field Service Engineer will note on the Customer Service Repair Report if decontamination was required and, if so, what the contaminant was and what procedure was used. If no decontamination was required, it will be so stated.

Section 2: INSTALLATION

After you receive your centrifuge, inspect it for damage before using it. The RC-5B PLUS centrifuge must be installed in a location that meets all of the location and electrical requirements specified in this section. Installation instructions are on page 2-2.

2-1. Inspection

As soon as you receive your RC-5B PLUS you should carefully inspect it for any shipping damage that may have occurred. If you find any damage, please report it immediately to the transportation company and file a damage claim, then notify DuPont. If any parts are missing, contact one of the DuPont district offices or the local representative of SORVALL® Products. You will find a list of offices in the back of this manual.

2-2. Location Requirements

The location of the centrifuge should be carefully considered because free air circulation is very important for the centrifuge to function properly. To allow adequate air circulation, locate the centrifuge in an area that will allow 10 cm (4 in) clearance between the wall and the sides of the centrifuge and has an ambient temperature within 15°C to 38°C. If the inlet air temperature is above 25°C, the centrifuge may not maintain low temperatures at high speeds.

When the centrifuge is situated at its operating location, install it as specified later in this section.

2-3. Electrical Requirements

The appropriate single-phase power source must be available to plug the centrifuge into. Check the nameplate on the back panel of the centrifuge to determine the electrical configuration of your centrifuge, which is one of the following:

240 V, 50 Hz, 30 A*
230 V, 60 Hz, 30 A*
220 V, 50 Hz, 30 A*
208 V, 60 Hz, 30 A*
200 V, 60 Hz, 30 A*
208 V, 60 Hz, 50 A*
230 V, 60 Hz, 50 A*

*CSA and UL approval is applied for.

Instruments shipped to Canada are shipped without a power cord (see paragraph 2-5).

To connect the centrifuge to a voltage other than what is specified on the nameplate (including polyphase), it will have to be rewired and its power cord may have to be replaced. Contact DuPont to have a Field Service Engineer do the rewiring.

The centrifuge is equipped with a 3-wire power cord with a 3-prong grounded plug (NEMA 6-30P) that fits NEMA receptacle 6-30R or equivalent. (Centrifuges shipped to Canada are supplied with a power cord to fit a NEMA 6-50R receptacle or equivalent.) For connection to other receptacles, the power cord may have to be replaced. Follow local electrical codes.



CAUTION

The centrifuge can be damaged if it is connected to a line voltage that varies more than $\pm 10\%$ of its nominal value. Check the voltage before plugging the centrifuge into any power source. DuPont is not responsible for improper installation.

If the line voltage varies by more than ± 10 , it may damage the centrifuge. **Read the CAUTION.**

The main power ON/OFF switch is a 30 A circuit breaker; therefore, a separate line disconnect switch is not needed unless required by local codes.

2-4. Installation

To install the centrifuge:

1. *If you are installing a new centrifuge, remove any packaging.*
2. Roll centrifuge into position. Open the chamber door by following the emergency sample recovery procedure in Section 11.
3. Install a rotor **WITHOUT** its lid. Place a level on the center hub of the rotor.
4. Turn the two front feet with the 9/16-inch wrench provided until they bear weight. Alternately turn the feet with the wrench to raise or lower the feet until the centrifuge is level. Remove the level. **Read the CAUTION.**
5. Plug the centrifuge into the appropriate electrical outlet.



CAUTION

The centrifuge can be seriously damaged if it is operated when it is not level.

2-5. Rewiring the Centrifuge

When converting either a 60 Hz or 50 Hz centrifuge to any voltage, connect wire 210 on TB101 as follows:

Input Voltage	TB101 Terminal
200	TB101-3
208	TB101-4
220	TB101-5
230	TB101-6
240	TB101-7

When converting a centrifuge from either 60 Hz to 50 Hz or from 50 Hz to 60 Hz, refer to the chart above. For 50 Hz conversion, move wire #143 to TB101-3; for 60 Hz conversion move wire #143 to TB101-6.

Refer to System Wiring Diagram, figure 5-1.



WARNING

Tampering with the high voltage electrical circuits in this centrifuge can cause severe electrical shock: this procedure must be performed by a qualified electrician only.

Conversion to Single Phase Permanent Wiring

This procedure applies to instruments shipped to Canada.

Connect the incoming power lines to the centrifuge as follows:

1. Set the main circuit breaker, POWER switch, to OFF.
2. Disconnect the power cord from the power supply.
3. Remove the right cabinet panel from the centrifuge.
4. Connect the safety ground wire to the lug connector marked GND  , figure 2-1 (on the next page).
5. Connect the incoming ac power wire to TB102-1.
6. Connect the ac power return wire to TB102-2.
7. Reinstall right cabinet panel.

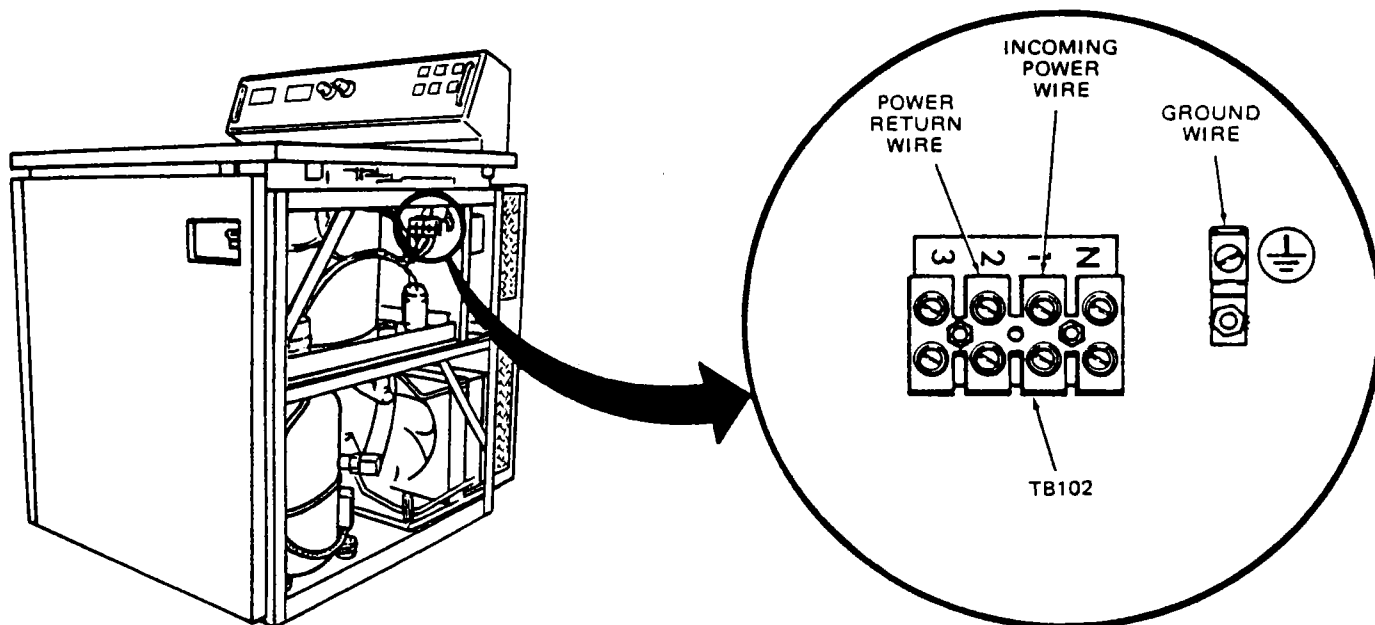

Figure 2-1. Single Phase Permanent Wiring

2-6. Test Run Procedure

After completing installation/rewiring of the centrifuge, perform a test run.

1. Ensure that the centrifuge is connected to a power supply and that the main circuit breaker, POWER switch, is set to ON.
2. Set up the centrifuge as follows:
 - a. Set SPEED dial to 10 000.
 - b. Set TEMPERATURE needles to 0°C.
 - c. Set TIME dial to HOLD.
 - d. Set BRAKE switch ON.
 - e. Install SS-34 rotor in centrifuge.

3. Close the centrifuge chamber door.
4. Press the START switch.
5. Verify the following:
 - The rotor acceleration rate is slow and even.
 - The set speed is maintained within 1%.
 - The set temperature is maintained within 1°C.
6. Set the TIME dial for one minute. Verify that the rotor starts to decelerate after one minute.
7. Press the STOP switch.
8. When the rotor stops, remove it from the centrifuge.
9. Record the test run parameters.

Section 3: OPERATION

This section describes the RC-5B centrifuge controls, and includes their locations and functions. It also provides step-by-step instructions on how to set the centrifuge power ON, open the chamber door, and perform a run, and how to precool the rotor.

3-1. Setting the Centrifuge Power On

The centrifuge power ON/OFF switch is located on the front panel, below the control panel. Press the top of the switch to set the centrifuge power on.

NOTE Upon start-up, an imbalance fault is indicated until the door is opened.

3-2. Opening the Chamber Door

Press the door release button located under the top deck (see figure 1-1) to release the door latch and open the chamber door.

3-3. Centrifuge Controls Description

The RC-5B PLUS control panel is used to select desired run parameters and, during a run, indicate actual run conditions, such as chamber temperature, rotor speed, and remaining or elapsed run time. The control panel light turns on, as required, to indicate that the power is ON, the brake is ON, the centrifuge detects a rotor imbalance, the brushes are worn and need to be replaced, or the door can be opened.

Refer to figure 3-1 for the location of the controls described in this chapter. The figure is keyed to Table 3-1.

Table 3-1. Centrifuge Controls

Item Number	Name	Function
1	TEMPERATURE Control and Meter	The refrigeration system automatically maintains the chamber temperature when the power is ON. During a run, the blue needle selects the desired chamber temperature and the red needle selects the maximum allowable temperature (overtemperature). When the timer is off (centrifuge is in standby or decelerating), the red needle selects the chamber temperature. The black needle indicates actual temperature in the rotor chamber. If the black needle indicates a temperature 3°C or greater than the red needle, the run will not start or, if a run is in progress, the run will terminate.
2	SPEED Dial and Meter	This dial is used to set desired run speed (in rpm). The meter shows actual rotor speed during a run.
3	TIME Dial	This dial is used to select the desired length of a run, up to 120 minutes for a timed run or continuous if set at HOLD. The STOP setting is selected to end a run in HOLD or to end a timed run before the selected time has elapsed.
4	START Switch and Light	When the START switch is pressed, the run will begin and the START light will turn on.
5	BRAKE Switch and Light	Press the BRAKE switch to set the brake either ON or OFF. If the BRAKE light is on, the brake is set ON and the rotor will brake (rather than coast) at the end of the run. If the BRAKE light is OFF, rotor will coast to a stop.
6	POWER Light	The POWER light will turn on (red) when the main POWER switch is set ON.
7	DOOR Light	The DOOR light will turn on when rotor speed is below approximately 100 rpm during deceleration, indicating that the chamber door can be opened.
8	BRUSHES Light	The BRUSHES light will turn on when the motor brushes are worn and must be replaced; the run in progress will continue, but a new run cannot be started.
9	IMBALANCE Light	The IMBALANCE light will turn on when a rotor imbalance occurs; the run in progress will terminate.
	POWER Switch	The POWER switch applies main power to the centrifuge when set to ON. It is located on the front panel.
	DOOR Button	Press the DOOR button and lift the door handle to open the door. It is located on the front panel.

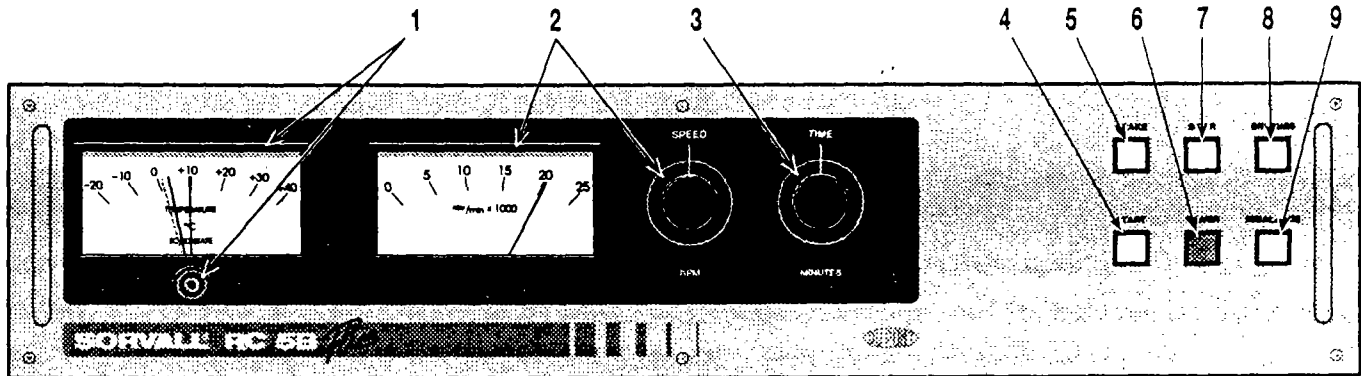

Figure 3-1. RC-5B PLUS Control Panel

3-4. Centrifuge Operation



WARNING

Do not exceed the recommended design mass for the maximum speed of the rotor in use. If design mass is exceeded, the operating speed must be reduced accordingly. (See rotor instruction manual for design mass and instruction on how to reduce speed in proportion to actual mass.)

Load and balance the rotor according to the instructions in the rotor manual, then operate the centrifuge as follows (refer to Table 3-1):

1. Set the POWER switch to ON. Upon start-up, an imbalance fault is indicated until the door is opened.
2. Push the DOOR button and open the chamber door.

NOTE Before installing the rotor, make sure that the rotor centerhole and the tapered spindle are clean and free of nicks or scratches. Wipe surfaces clean before each operation to reduce the chance of the rotor sticking to the spindle.

If the chamber temperature is below room temperature and the rotor has not been precooled, allow time for the rotor to cool to the chamber temperature before locking it in place.

3. Install the rotor. Make sure it is locked to the drive.
4. Close the chamber door.
5. Set the TEMPERATURE needles to the desired settings.

NOTE To achieve the desired rotor temperature, follow the procedure in *Rotor Speed and Temperature Differential Compensation* to set the proper chamber temperature.

6. Turn the TIME dial to the desired run time setting or to HOLD.

7. Turn the SPEED dial to the desired run speed setting.
8. If you want the rotor to brake at the end of the run, set the brake ON by pressing the BRAKE switch so that the light is on.
9. Press the START switch. The centrifuge will accelerate to the selected speed and run for the selected time. The run will coast or brake to a stop when the time expires.

NOTE If it is necessary to stop the rotor during HOLD or before the selected time has elapsed, always turn the TIME control dial to STOP. DO NOT stop the rotor by turning the SPEED dial to 0 rpm.

If a power interruption occurs during a run, the run can be continued by pressing the START switch.

During deceleration, the chamber temperature will be controlled by the red temperature needle setpoint (standby).

When the rotor has decelerated below 100 rpm, the DOOR light will turn on. The chamber door can then be opened by pushing the DOOR button and lifting the door handle. Remove the rotor.

3-5. Rotor Speed/Temperature Differential Compensation

Graphs



CAUTION

The temperature offset technique should be used on all runs to prevent overtemperature or freezing of sample. This is particularly important at low set temperatures and at speeds lower than maximum rotor speed.

To create a graph, plot the selected temperature versus the actual sample temperature at a specific speed and ambient condition. For example: To achieve and maintain a +7.5°C sample temperature with a GSA Rotor at 13 000 rpm, the blue needle must be set at approximately +4°C, which is 3°C colder than the desired temperature.

NOTE An ambient temperature of 25°C or less is required to obtain optimum cooling efficiency. At higher ambient temperatures, a lower operating speed may be necessary to maintain sample temperature.

Test Run Procedure

More accurate temperature offset data can be obtained by doing a test run and dynamically calibrating a specific rotor/centrifuge/desired speed combination and ambient condition. Using an immersible centigrade thermometer calibrated in 1.0°C increments, perform the procedure given on the next page.

1. Select the desired sample temperature.
2. Prepare two tubes or bottles of dispensable fluid. Balance according to instructions in rotor instruction manual.

NOTE The dispensable fluid should have a freezing point somewhat below the desired sample temperature.

3. Precool the thermometer to 1.0°C below the desired sample temperature.
4. Set the blue TEMPERATURE select needle to the desired sample temperature.
5. Install the empty rotor in the centrifuge, and precool the rotor.
6. When precool time has elapsed, load the prepared tubes or bottles into the rotor, and run the rotor for at least one hour at the desired speed.
7. When the run time has elapsed and the rotor has stopped, open the chamber door; then open one rotor compartment, and immerse the precooled thermometer into the liquid. Agitate the thermometer in the liquid for approximately five (5) to ten (10) seconds. Record the indicated temperature.
8. Adjust the blue TEMPERATURE select needle according to the recorded temperature indication. For example: if the recorded temperature is 2°C warmer than the desired temperature, reset the blue TEMPERATURE select needle downward 2°C.
9. Record all data for future use.

NOTE Although the indicated chamber temperature could vary some 2°C during a run, the actual temperature will vary only a few tenths of a degree. In the standby mode, indicated temperature could vary 10°C, with an actual chamber temperature change of $\pm 1^\circ\text{C}$.

3-6. Precautions to Prevent Samples from Freezing

If a sample freezes, it is not necessarily caused by a malfunction of the centrifuge. Because of the high capacity of the refrigeration system, certain operating conditions can cause a sample to freeze. However, you can prevent this from happening by using the proper technique.

Freezing will occur when the following three conditions happen simultaneously:

1. The speed setting is below 7000 rpm.
2. The blue temperature select needle is set below 5°C.
3. The black temperature indicator needle is several degrees above the setting of the blue needle.

When these conditions occur simultaneously, the temperature control system senses a need to reduce the chamber temperature several degrees. As a result, the refrigeration system is set ON, causing liquid refrigerant to enter the evaporator. However, heat is not being generated at a balanced rate in the rotor chamber, so the refrigerant entering the evaporator is more than what is needed to absorb heat from the chamber. As the refrigerant absorbs the heat, naturally, the chamber temperature drops. When the temperature has dropped to the point where the black needle crosses the blue needle, the compressor will shut off. However, the excess refrigerant in the evaporator continues to absorb heat from the chamber. This will lower the chamber temperature several degrees below the desired temperature, and the sample may freeze.

The problem can be overcome in three ways, all of which involve stabilizing the actual chamber temperature (indicated by the black needle) at or below the blue needle setpoint before the run begins. Please try one of the following methods before notifying your Field Service Engineer.

1. Perform the run with the red and the blue needles at the same temperature setting (one needle directly over the other). In this way, when the TEMPERATURE control switches to the red needle setting during standby, the temperature will not rise, so Condition 3 will not occur.
2. Set the blue needle at the desired run temperature. Install an empty rotor, and operate it at approximately one-half its maximum rated speed until the black indicator needle stabilizes near the blue needle. Then, stop the centrifuge and load the rotor. DO NOT adjust the blue needle. Set the SPEED dial at the desired run speed (below 7000 rpm) and restart the centrifuge.
3. During a short run, the temperature of the rotor and the evaporator will not change much. Therefore, if your run is to be less than 15 minutes, stabilize the temperature to a desired level using method 1 or 2, then when ready to begin the run, turn the red and the blue needles to the highest setting. The refrigeration system will not function during the run, but temperature rise will be minimal. Do a trial run at the desired conditions to see if the temperature rise is acceptable.

Using the methods outlined above will minimize the chance of samples freezing.

3-7. Rotor Precool

If you plan to run a temperature-sensitive sample in the RC-5B PLUS centrifuge, we recommend that you precool the rotor and the centrifuge before loading the sample. This will ensure that the rotor and chamber temperatures are at equilibrium at the start of the run.



CAUTION

Failure to load and install the rotor in accordance with the rotor instruction manual could result in damage to the centrifuge. The rotor cover must be on and locked in place and the rotor must be locked to the drive spindle.

1. Set the centrifuge power ON and open the chamber door.
2. Install the empty rotor (with cover installed, if applicable). Lock it to the drive spindle by turning the rotor locking screw counterclockwise. Close the chamber door.
3. Set a run speed of 2000 rpm.
4. Set the TIME dial to HOLD.
5. Set the TEMPERATURE needles for desired run temperature.
6. Set all other controls as you would for a normal mode run.
7. Press the START switch. The rotor will accelerate to 2000 rpm and quickly cool to the selected run temperature. It will typically take the rotor 30 minutes to cool, but the actual time will vary depending on the rotor weight and rotor material.

When the displayed temperature equals the run temperature setting, stop the run.

8. After the rotor has come to a stop, open the chamber door and remove the rotor lid. Place the samples in the rotor and balance the load as specified in the rotor instruction manual.
9. Re-secure the rotor lid. Lock the rotor to the drive spindle. Close the chamber door.
10. Perform the desired centrifuge run.

3-8. Troubleshooting

Refer to Table 3-2 for possible causes and corrective actions to problems that occur either before or during a run.

Table 3-2. Troubleshooting

Problem	Possible Cause(s)	Suggested Corrective Action
Centrifuge will not start	The actual chamber temperature indicated by the black needle is 3° greater than the overtemperature set by the red temperature needle.	Set the red needle above the black needle or let the chamber cool before pressing START.
	Chamber door is open.	Close the chamber door.
	Main power is set OFF.	Set the POWER switch ON.
Run terminated	Power failure or interruption occurred.	Restart the run when power is restored.
	Chamber overtemperature occurred during the run.	Precool the rotor and chamber before starting run.
		Refrigeration system failure. Contact Service Engineer.
	Rotor imbalance occurred.	Balance rotor and restart the run.
	Overspeed condition caused by lack of rotor.	Install rotor and restart run.
BRUSHES light is on	Brushes are worn.	Replace brushes before starting a new run.
IMBAL light is on	Rotor imbalance occurred.	Balance rotor and restart the run
Door will not open	Power failure occurred.	Open chamber door manually (see <i>Emergency Sample Recovery</i> in Section 11).

3-9. Reducing Speed for Loads in Excess of Design Mass

There is a maximum allowable compartment mass established for each rotor (see the Rotor Information Table in Section 5 or the individual rotor manual). To prevent rotor failure, the total contents of any compartment, including specimen, tubes, sealing assembly, and adapters (if used), must not exceed the specified maximum compartment mass unless rotor speed is reduced proportionately.



WARNING

Failure to reduce rotor speed when compartment load exceeds maximum allowable compartment load can lead to rotor failure.

Strict adherence to the maximum allowable compartment mass or reduced rotor speed is required to prevent rotor failure. **Read the WARNING.**

If the maximum compartment mass is greater than the value specified for the rotor, use the following formula to determine the reduced rotor speed that is required:

$$\text{Reduced Speed} = \text{Maximum Rotor Speed} \times \sqrt{\frac{\text{Maximum Compartment Mass}}{\text{Actual Compartment Mass}}}$$

Section 4: SPECIFICATIONS

This section contains centrifuge specifications and rotor information for the SORVALL[®] RC-5B PLUS Superspeed Refrigerated Centrifuge.

NOTE Centrifuge specifications may vary depending on the rotor being used.

4-1. Centrifuge Specifications

Run Speed¹

Speed Selection Range (rpm)	500 to 21 000
Speed Control Accuracy	±1% or 100 rpm, whichever is greater

Maximum Relative Centrifugal Force

(using the F-20/MICRO Rotor)	51 070 g
--	----------

Run Temperature

Temperature Selection Range	-20 to +40°C
Temperature Control Range	-15 to +30°C ^{2,3}
Temperature Control Accuracy	±1°C ^{3,4}

Run Time Selection Range	0 to 120 minutes or Hold
------------------------------------	-----------------------------

Ambient Temperature Range	+15 to +38°C ³
-------------------------------------	---------------------------

Mass (Weight)	308 kg (680 lb)
-------------------------	-----------------

Dimensions

Width	76 cm (30 in)
Height to top of control console	114 cm (45 in)
Depth	99 cm (39 in)

Electrical Requirements

Input Power (single phase, 30 A)	240 V, 50 Hz 230 V, 60 Hz 220 V, 50 Hz 208 V, 60 Hz 200 V, 60 Hz
--	--

(continued on next page)

1 Speed in revolutions per minute (rpm) is related to angular velocity, ω , according to the following:

$$\omega = (\text{rpm}) \left(\frac{2\pi}{60} \right) = (\text{rpm}) (0.10472)$$

Where ω = rad/s. All further references in this manual to speed will be designated as rpm.

2 May vary at very low speeds (below approximately 2000 rpm).

3 The centrifuge will operate at ambient temperatures up to 38°C, but refrigeration system performance may be less than optimal above 25°C.

4 After the centrifuge system has reached equilibrium.

4-1. Centrifuge Specifications (continued)

Input Power (polyphase, 3ØA) 220V, 50Hz
Receptacle NEMA 6-30R
(for NEMA 6-30P grounded plug that is supplied)

Maximum Noise Level <62 dB¹

Heat Output 4.8 kW²
(16 500 Btu/h²)

1 For the SS-34 rotor at 20 000 rpm.

2 For the SS-34 rotor spinning 20 000 rpm at 4°C, after it has reached equilibrium. Other rotors, speeds, and temperatures cause the heat output to vary.

Rotor Information Table



WARNING

The SORVALL[®] RC-5B PLUS can be used with SORVALL[®] rotors *only*. Use of another manufacturer's rotor can cause rotor failure which could result in personal injury and/or centrifuge damage.

ROTOR	MAX SPEED (rpm)	CRITICAL SPEED (rpm)	MAX RCF	K FACTOR	MAX COMPART- MENT MASS	RADIUS	
						MAX (cm)	MIN (cm)
GS-3	9000	750	13 689	4201	780.0 g	15.13	3.93
SA-600	16 500	1200	39 411	792	115.0 g	12.96	5.52
SS-34	20 000	1350	47 807	752	115.0 g	10.70	3.26
SE-12	21 000	1700	45 959	513	30.0 g	9.33	3.81
HB-4	13 000	1200	27 579	1678	250.0 g	14.61	4.75
HS-4	7000	1000	9 425	4495	1035.0 g	17.22	7.21
SM-24	20 000	1300	49 460 ²	457 ²	27.0 g	11.07 ²	5.37 ²
GSA	13 000	900	27 504	2019	580.0 g	14.57	3.77
TZ-28 ³	19 000	1000	42 535	605	1620.0 g	9.52	3.65
SH-MT	13 730 ⁴	1600	19 140 ⁴	656 ⁴	36.4 g	9.09 ⁴	5.57 ⁴
SH-80	20 000	700	45 394	399	78.0 g	10.16	5.40
F-28/13	19 500	1300	48 547	295	23.0 g	11.43	7.34
F-28/36	18 000	1300	41 366	480	66.0 g	11.43	6.18
S-20/36	8 000	400	11 509	2916	156.6 g	16.10	7.70
S-20/20	12 000	400	20 910	831	115.1 g	13.00	8.10
S-20/17	8 000	400	11 867	3587	130.1 g	16.60	6.70
F-16/250	14 000	900	29 774	1694	420.0 g	13.60	3.66
HB-6	13 000	1000	27 617	1765	164.0 g	14.63	4.50
F-28/50	19 500	1240	48 717	694	115.0 g	11.47	4.04
F-20/MICRO	20 000	1200	51 070	196.3	3.0 g	11.43	8.38
SA-300	21 000	1100	47 634	822	115.0 g	9.58	2.14
SLA-1000	16 500	800	35 792	1727	400.0 g	11.77	7.54

¹ With maximum allowable volume at maximum speed.

² Outer row

³ Continuous flow configuration only

⁴ Maximum speed of rotor is 20 000 rpm; actual maximum speed depends on tubes. Values given are typical for 1.5 ml microtubes.

Section 5: PRINTED CIRCUIT BOARDS and SCHEMATIC DIAGRAMS

This section contains a system diagram as well as schematic diagrams and component description tables for printed circuit boards found in the RC-5B PLUS Centrifuge.

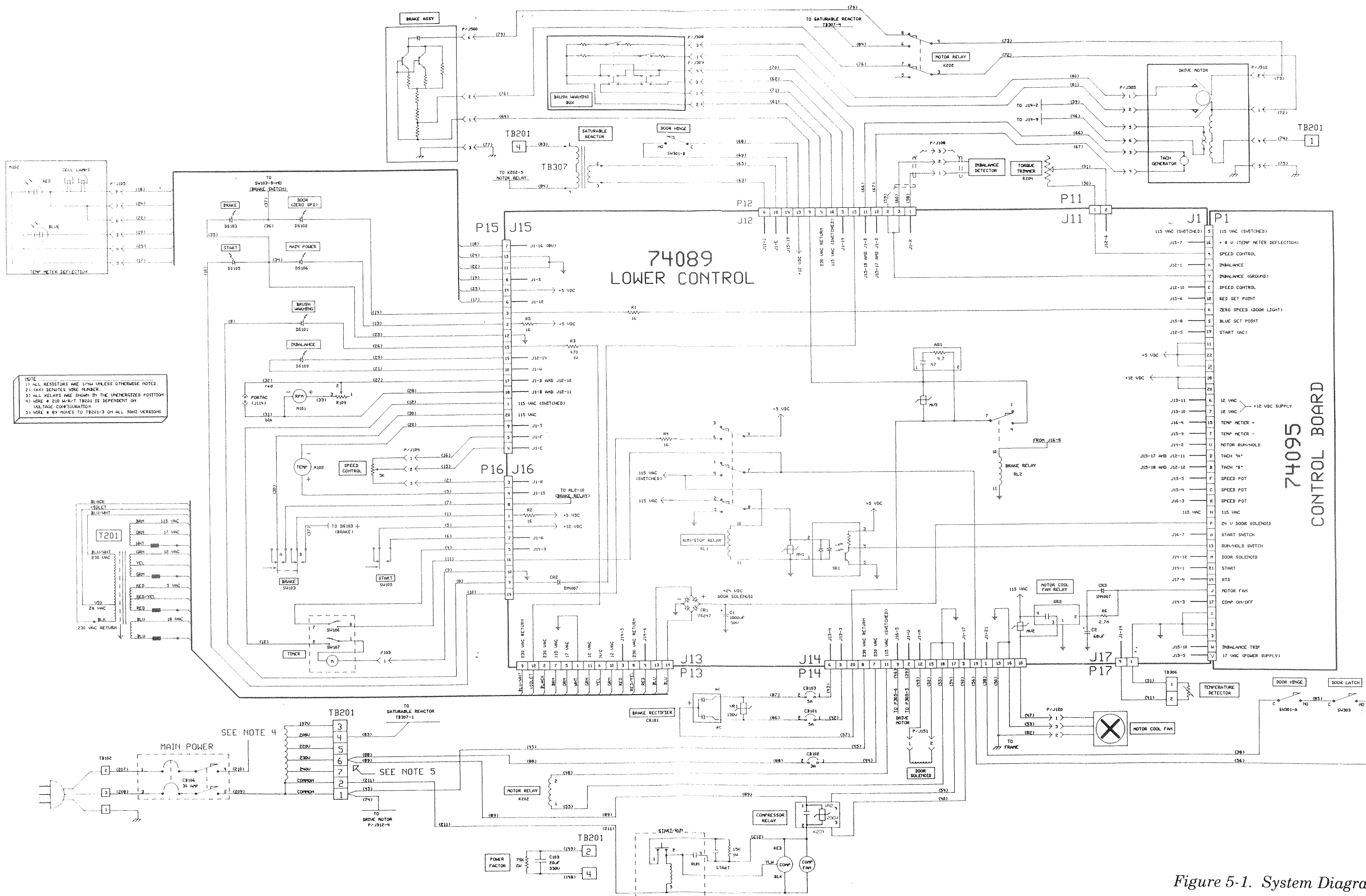

Figure 5-1. System Diagram

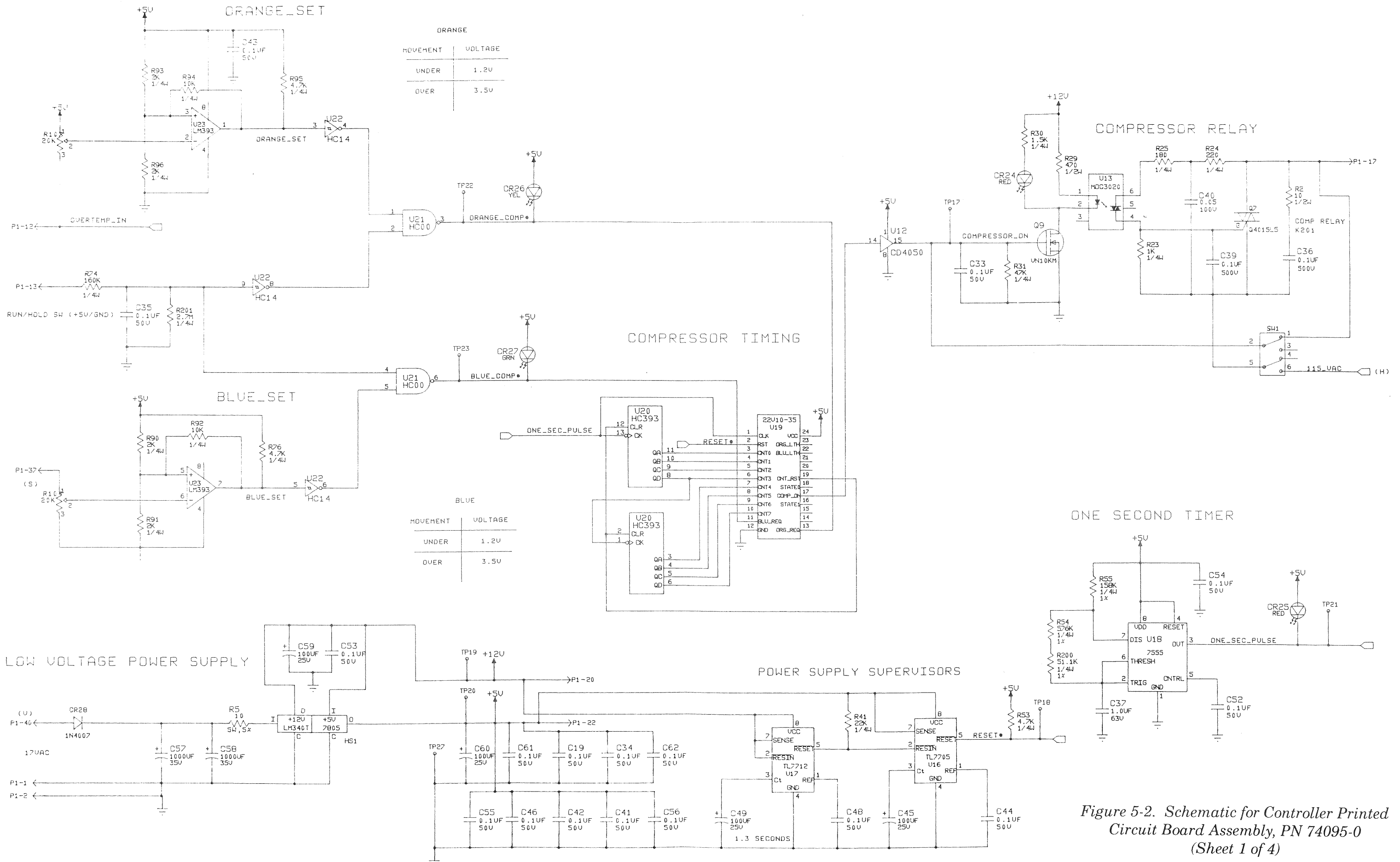
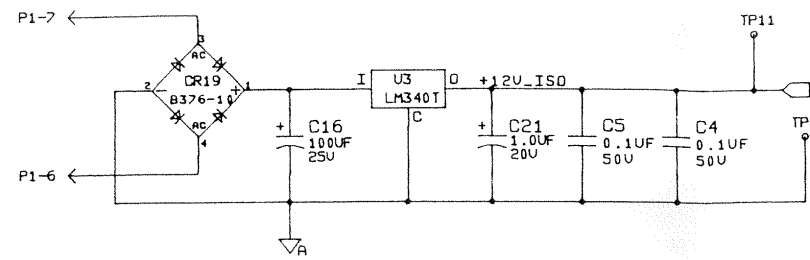

Figure 5-2. Schematic for Controller Printed Circuit Board Assembly, PN 74095-0 (Sheet 1 of 4)

TACH RESPONSE

FREQUENCY	VOLTAGE	SPEED
330	30	20K
33	3	2K
16	1.5	1K
1.6	.15	100
.8	.075	10



ZEROSPEED

ZEROSPEED=1.125V @ 50 RPM

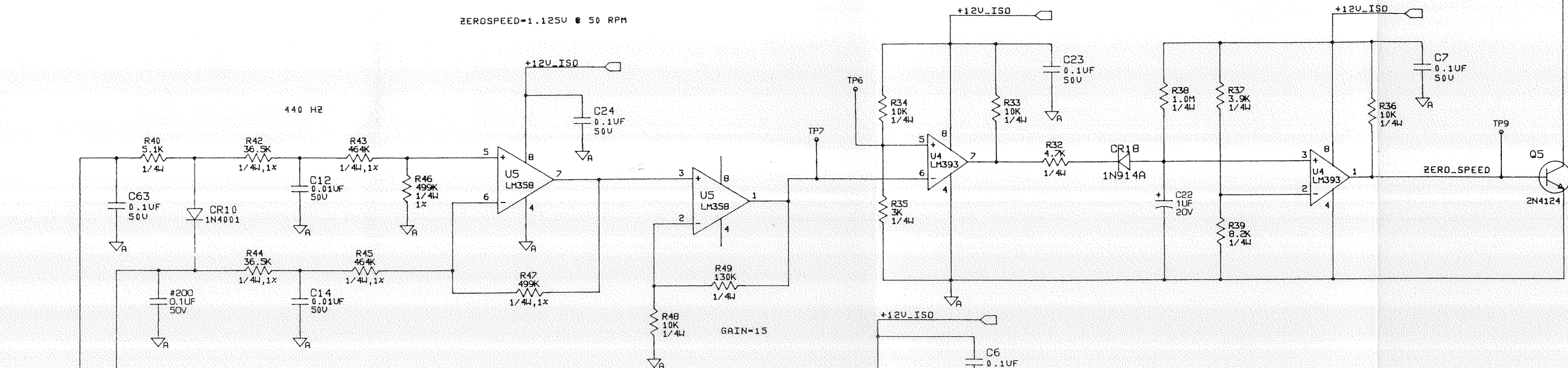

OVERSPEED

OVERSPEED = 0.39V

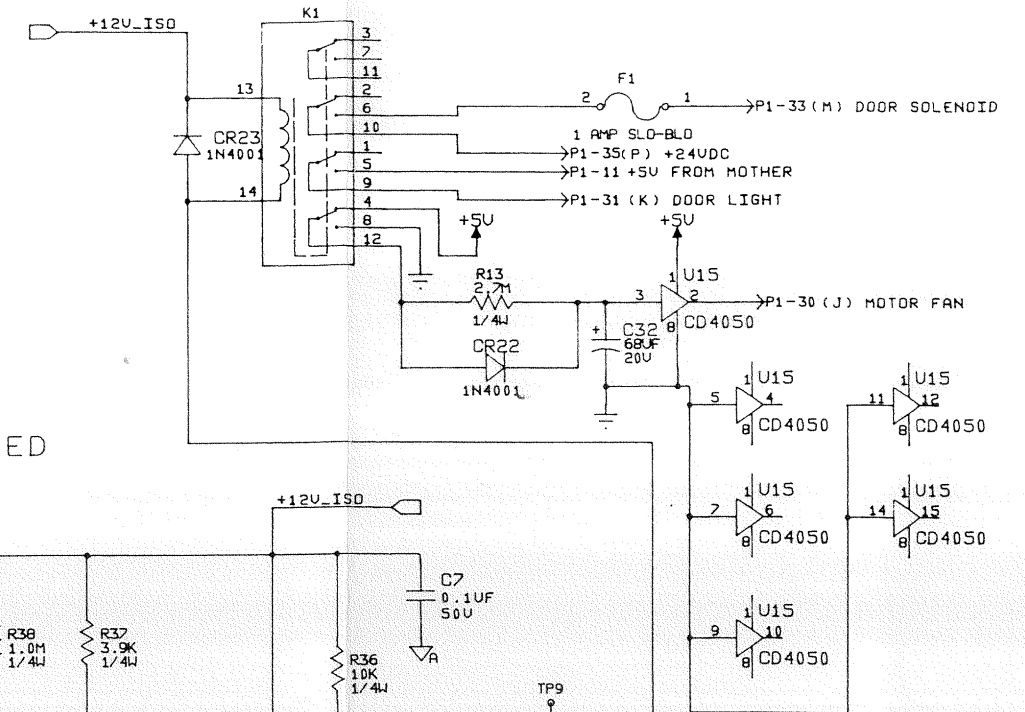
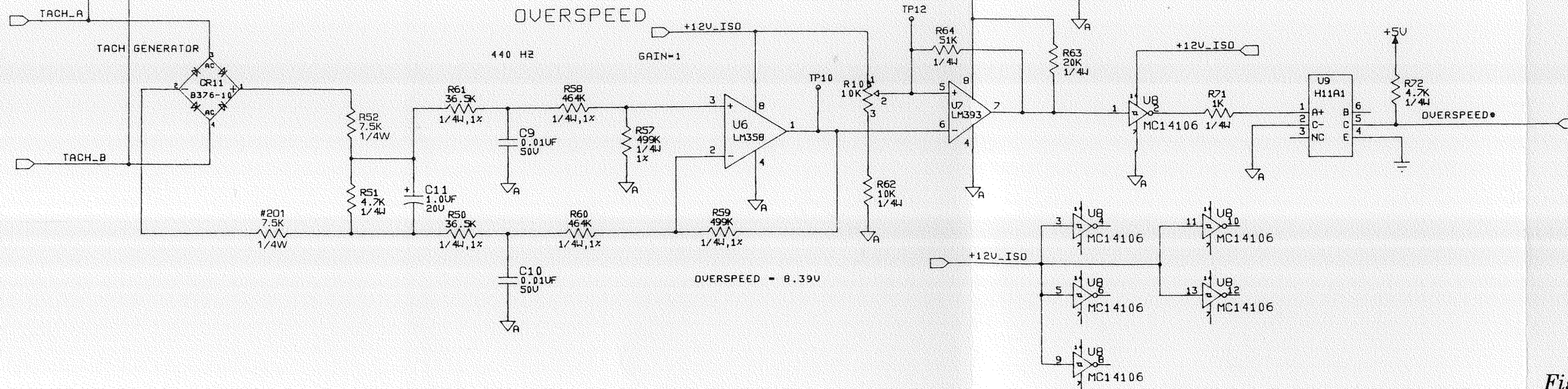
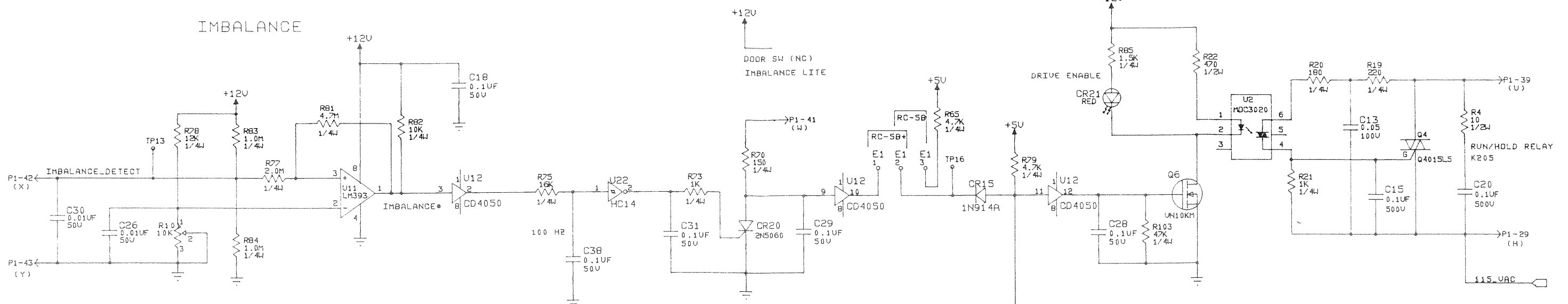
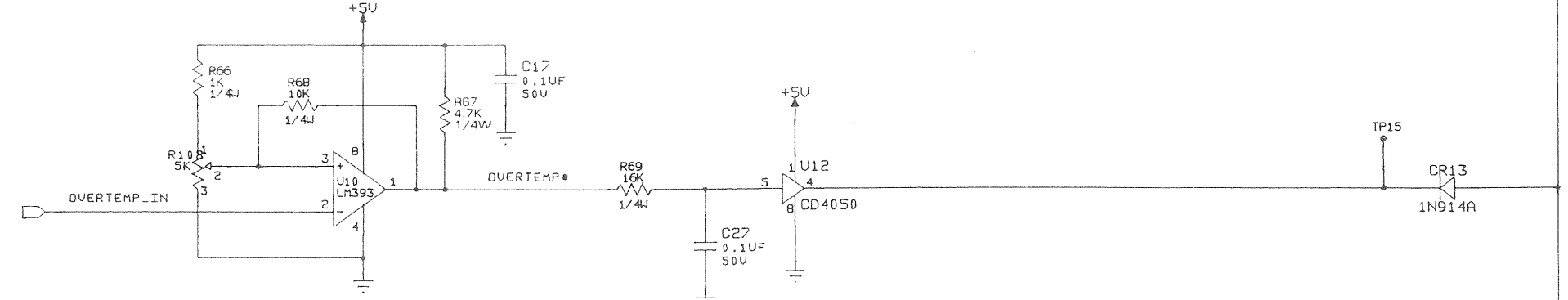

Figure 5-2. Schematic for Controller Printed Circuit Board Assembly, PN 74095-0 (Sheet 2 of 4)

LATCHING CIRCUIT



OVERTEMP



METER DEFLECTION

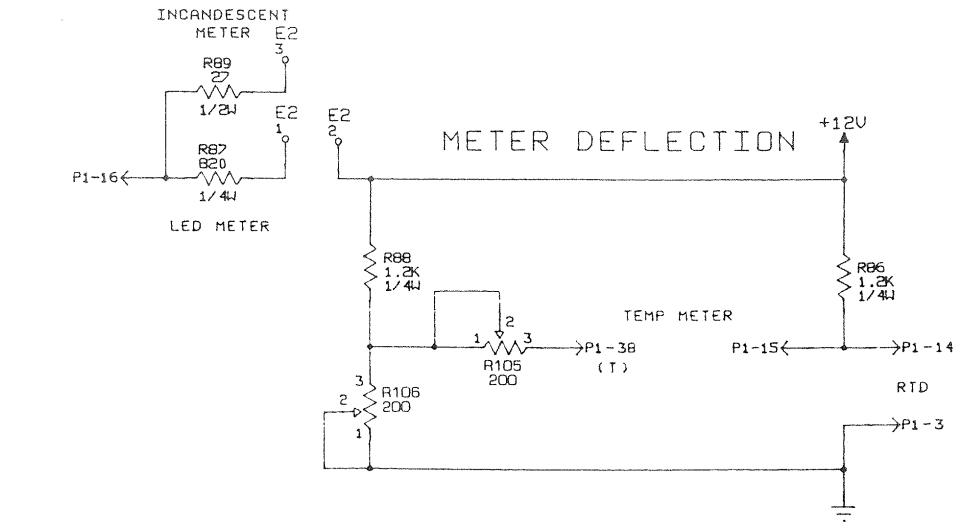

REMOTE START CIRCUIT

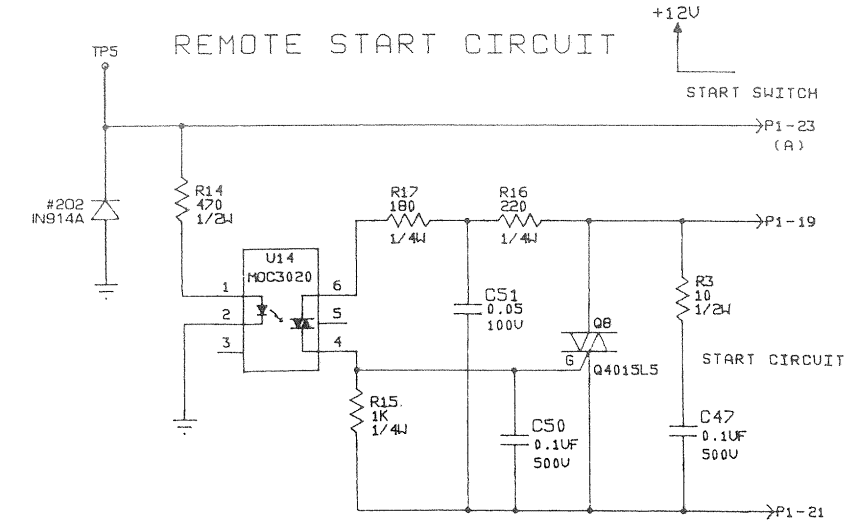

Figure 5-2. Schematic for Controller Printed Circuit Board Assembly, PN 74095-0 (Sheet 3 of 4)

SPEED CONTROL

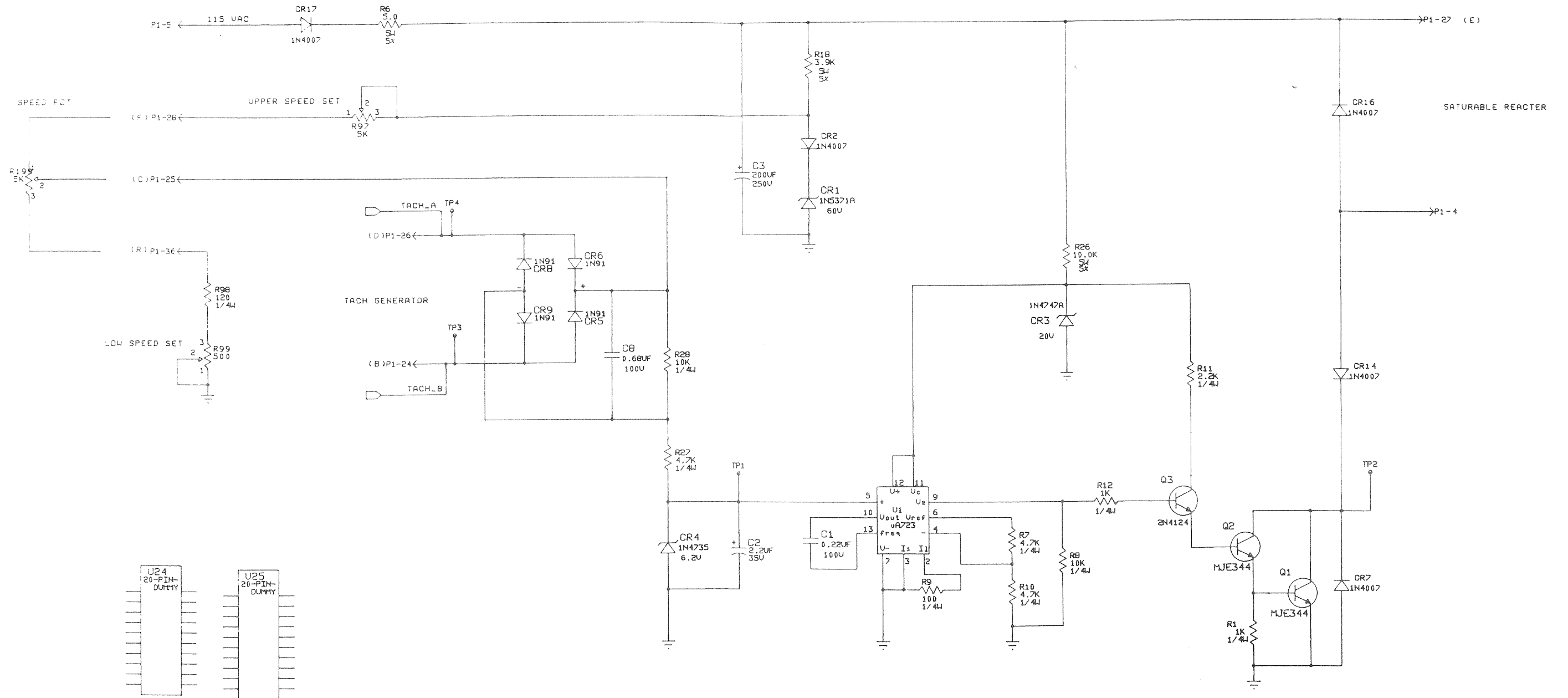

Figure 5-2. Schematic for Controller Printed Circuit Board Assembly, PN 74095-0 (Sheet 4 of 4)

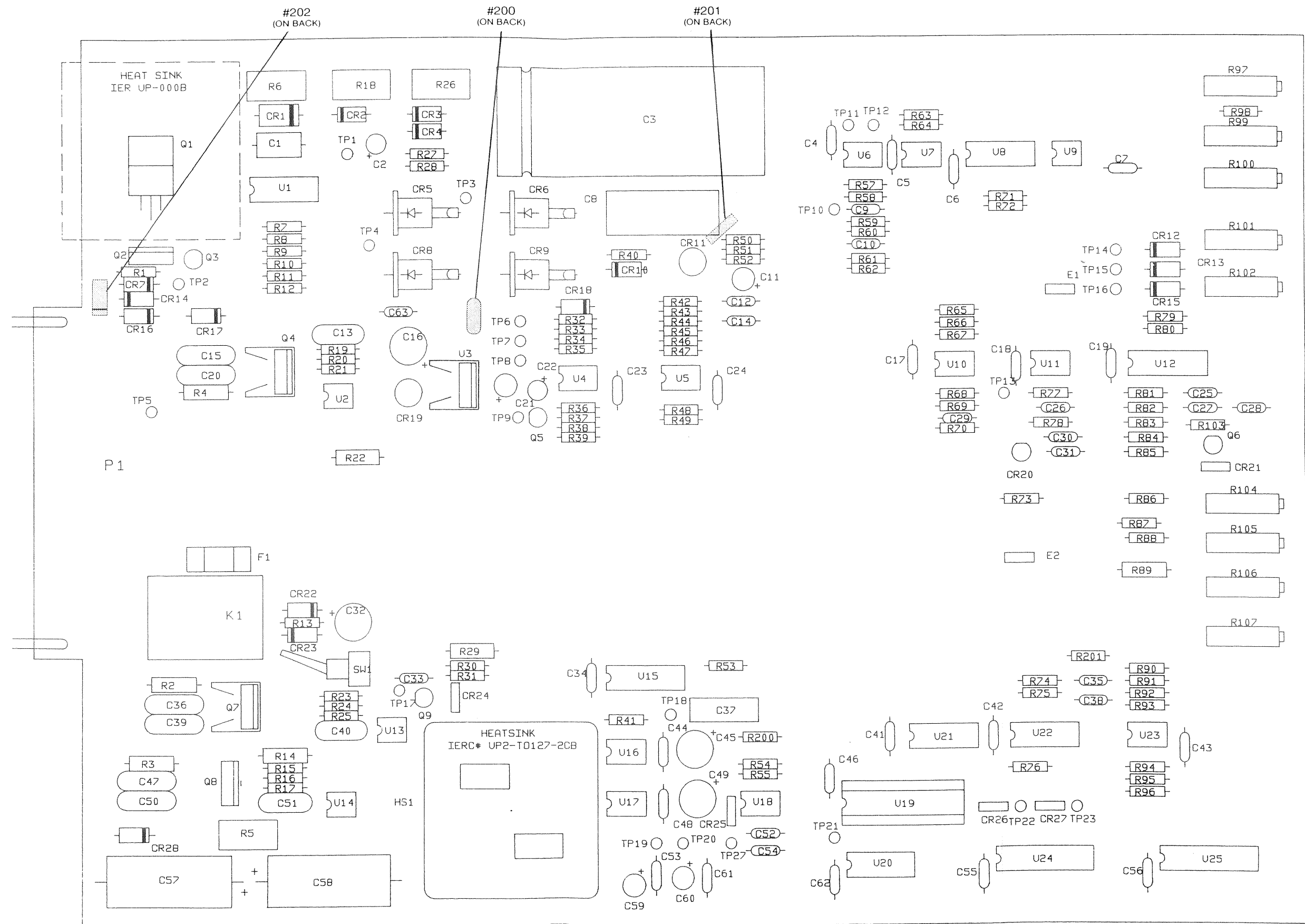

Figure 5-3. Component Location, Controller Printed Circuit Board, PN 74095-0

**Table 5-1. Component Description,
Controller Printed Circuit Board, PN 74095-0 12987**
(refer to figure 5-3)

Component	Description
C1	Capacitor, 0.22 μ F, 100V
C2	Capacitor, Tantalum, 2.2 μ F, 20%, 35V
C3	Capacitor, Electrolytic, 200 μ F, 250V
C4, C5, C6, C7, C17, C18, C19, C23, C24, C25, C27, C28, C29, C31, C33, C34, C35, C38, C41, C42, C43, C44, C46, C48, C52, C53, C54, C55, C56, C61, C62, C63, #200	Capacitor, CML, 0.1 μ F, \pm 20%, 50V
C8	Capacitor, 0.68 μ F, 100V
C9, C10, C12, C14	Capacitor, CML, 0.01 μ F, \pm 10%, 50V
C11, C21	Capacitor, Tantalum, 1.0 μ F, 20%, 20V
C13, C40, C51	Capacitor, 100V, 0.05 μ F, 20%
C15, C20, C36, C39, C47, C50	Capacitor, Ceramic Disc, 0.1 μ F, 500V, 10%
C16, C45, C49	Capacitor, 100 μ F, 20%, 25V
C22	Capacitor, Tantalum, 1 μ F, 20%, 20V
C26, C30	Capacitor, CML, 0.01 μ F, \pm 20%, 50V
C32	Capacitor, Tantalum, 68 μ F, 10%, 20V
C37	Capacitor, 1 μ F, 10%, 63V
C57, C58	Capacitor, 1000 μ F, \pm 20%, 35V
C59, C60	Capacitor, 100 μ F, 20%, 25V

**Table 5-1. Component Description,
Controller Printed Circuit Board, PN 74095-0 12987**
(refer to figure 5-3), continued

Component	Description
CR1	Diode, Zener, 60V, 5W, 10%, 25V
CR2, CR7, CR14, CR16, CR17, CR28	Diode, IN4007, 25V
CR3	Diode, Zener, 25V
CR4	Diode, Zener, 25V
CR5, CR6, CR8, CR9	Diode, Solid State, 1N91
CR10, CR22, CR23	Diode, Silicon, 1N4001
CR11, CR19	Silicon Bridge Rectifier, 1.5A, 100V
CR12, CR13, CR15, CR18, #202	Diode, Silicon 1N914A
CR20	Rectifier, Cont. Plastic
CR21, CR24, CR25	LED, Red, 5V
CR26	LED, Yellow, 5V
CR27	LED, Green, 5V
E1, E2	Jumper, 3-pin
F1	Fuse, 1 Amp - Slo
HS1, U3	Integrated Circuit, 12V Reg +12V 4% 1.5A to 220
K1	Midget Relay, 12V 160
Q1, Q2	Transistor, 0.5 Amp, NPN
Q3, Q5	Transistor, NPN
Q4, Q7, Q8	Triac, Isolated Tab
Q6, Q9	Transistor, Power FET

**Table 5-1. Component Description,
Controller Printed Circuit Board, PN 74095-0 12987**
(refer to figure 5-3), continued

Component	Description
R1, R12, R15, R21 R23, R66, R71, R73	Resistor, Carbon, 1 K Ω , 5%, 1/4W
R2, R3, R4	Resistor, Carbon, 10 Ω , 5%, 1/2W
R5	Resistor, 10 Ω , 5W, 5%
R6	Resistor, 5.0 Ω , 5W, 5%
R7, R10, R27, R32, R51, R53, R65, R72, R76, R79, R95	Resistor, Carbon, 4.7 K Ω , 5%, 1/4W
R8, R28, R33, R34, R36, R48, R62, R68, R82, R92, R94	Resistor, Carbon, 10 K Ω , 5%, 1/4W
R9	Resistor, Carbon, 100 Ω , 5%, 1/4W
R11	Resistor, Carbon, 2.2 K Ω , 5%, 1/4W
R13	Resistor, Carbon, 2.7 M Ω , 5%, 1/4W
R14, R22, R29	Resistor, Carbon, 470 Ω , 5%, 1/2W
R16, R19, R24	Resistor, Carbon, 220 Ω , 5%, 1/4W
R17, R20, R25	Resistor, Carbon, 180 Ω , 5%, 1/4W
R18	Resistor, 3.9 K Ω , 5W, 5%
R26	Resistor, 10 K Ω , 5W, 5%
R30, R85	Resistor, Carbon, 1.5 K Ω , 5%, 1/4W
R31, R103	Resistor, Carbon, 47 K Ω , 5%, 1/4W
R35	Resistor, Carbon, 3 K Ω , 5%, 1/4W
R37	Resistor, Carbon, 3.9 K Ω , 5%, 1/4W
R38, R83, R84	Resistor, Carbon, 1M Ω , 5%, 1/4W

**Table 5-1. Component Description,
Controller Printed Circuit Board, PN 74095-0** 12987
(refer to figure 5-3), continued

Component	Description
R39	Resistor, Carbon, 8.2 K Ω , 5%, 1/2W
R40	Resistor, Carbon, 5.1 K Ω , 1/4W
R41	Resistor, Carbon, 22 K Ω , 1/4W
R42, R44, R50, R61	Resistor, Metal Film, 36.5 K Ω , 1%, 1/4W
R43, R45, R58, R60	Resistor, Metal Film, 464 K Ω , 1%, 1/4W
R46, R47, R57, R59	Resistor, Metal Film, 499 K Ω , 1%, 1/4W
R49	Resistor, Carbon, 130 K Ω , 5%, 1/4W
R52, #201	Resistor, Carbon, 7.5 K Ω , 5%, 1/4W
R54	Resistor, Metal Film, 576 K Ω , 1%, 1/4W
R55	Resistor, Metal Film, 158 K Ω , 1%, 1/2W
R63	Resistor, Carbon, 20 K Ω , 5%, 1/4W
R64	Resistor, Carbon, 51 K Ω , 5%, 1/4W
R67	Resistor, Carbon, 4.7 K Ω , 5%, 1/4W
R69, R75, R80	Resistor, Carbon, 16 K Ω , 5%, 1/4W
R70	Resistor, Carbon, 150 Ω , 5%, 1/4W
R74	Resistor, Carbon, 160 K Ω , 5%, 1/4W
R77	Resistor, Carbon, 2 M Ω , 5%, 1/4W
R78	Resistor, Carbon, 12 K Ω , 5%, 1/4W
R81	Resistor, Carbon, 4.7 M Ω , 5%, 1/4W
R86, R88	Resistor, Carbon, 1.2 K Ω , 5%, 1/4W
R87	Resistor, Carbon, 820 Ω , 5%, 1/4W
R89	Resistor, Carbon, 27 Ω , 5%, 1/4W

**Table 5-1. Component Description,
Controller Printed Circuit Board, PN 74095-0** 12987
(refer to figure 5-3), continued

Component	Description
R90, R91, R93, R96	Resistor, Carbon, 2 K Ω , 5%, 1/2W
R97, R102, R199	Potentiometer, 5k, 3/8 Cermet
R98	Resistor, Carbon, 120 Ω , 5%, 1/4W
R99	Potentiometer, PCB, 500 Ω , 10%, 25T Cermet, 1/2W
R100, R101	Potentiometer, 10K, 3/8 Cermet
R104, R107	Potentiometer, 20K, 3/8 Cermet
R105, R106	Potentiometer, PCB, 200 Ω , 10% 25T Cermet, 1/2W
R201	Resistor, Carbon, 2.7 M Ω , 5%, 1/4W
SW1	Switch, Augat RA PCB DPDT
TP1, TP2, TP3, TP4, TP5, TP6, TP7, TP8, TP9, TP10, TP11, TP12, TP13, TP14, TP15, TP16, TP17, TP18, TP19, TP20, TP21, TP22, TP23, TP27	Test Point, P.C. Type, Cermet, 1/2W
U1	Integrated Circuit, Cermet, 1/2W
U2, U13, U14	Integrated Circuit, Opto-Coupler, ILED/Triac Driver
U4, U7, U10, U11, U23	Integrated Circuit, Comparator, Low Input V&I, LM393A
U5, U6	Integrated Circuit, Linear, LM358N
U8	Integrated Circuit, Hex Schmitt-Trigger Inverter
U9	Integrated Circuit, Opto-Coupler/Isolator, H11A1
U12, U15	Integrated Circuit, Hex Buffer
U16	Integrated Circuit, +5V Supply
U17	Integrated Circuit, +12V Supply

**Table 5-1. Component Description,
Controller Printed Circuit Board, PN 74095-0 12987**
(refer to figure 5-3), continued

Component	Description
U18	Integrated Circuit, CMOS, Timer
U19	Integrated Circuit, PAL-COMP-TIME, AMD 22V10-35
U20	Integrated Circuit, Dual Binary Counter, 4-Bit Ripple
U21	Integrated Circuit, Quad Nand Gate, 2 Input
U22	Integrated Circuit, Hex Schmitt-Trigger Inverter

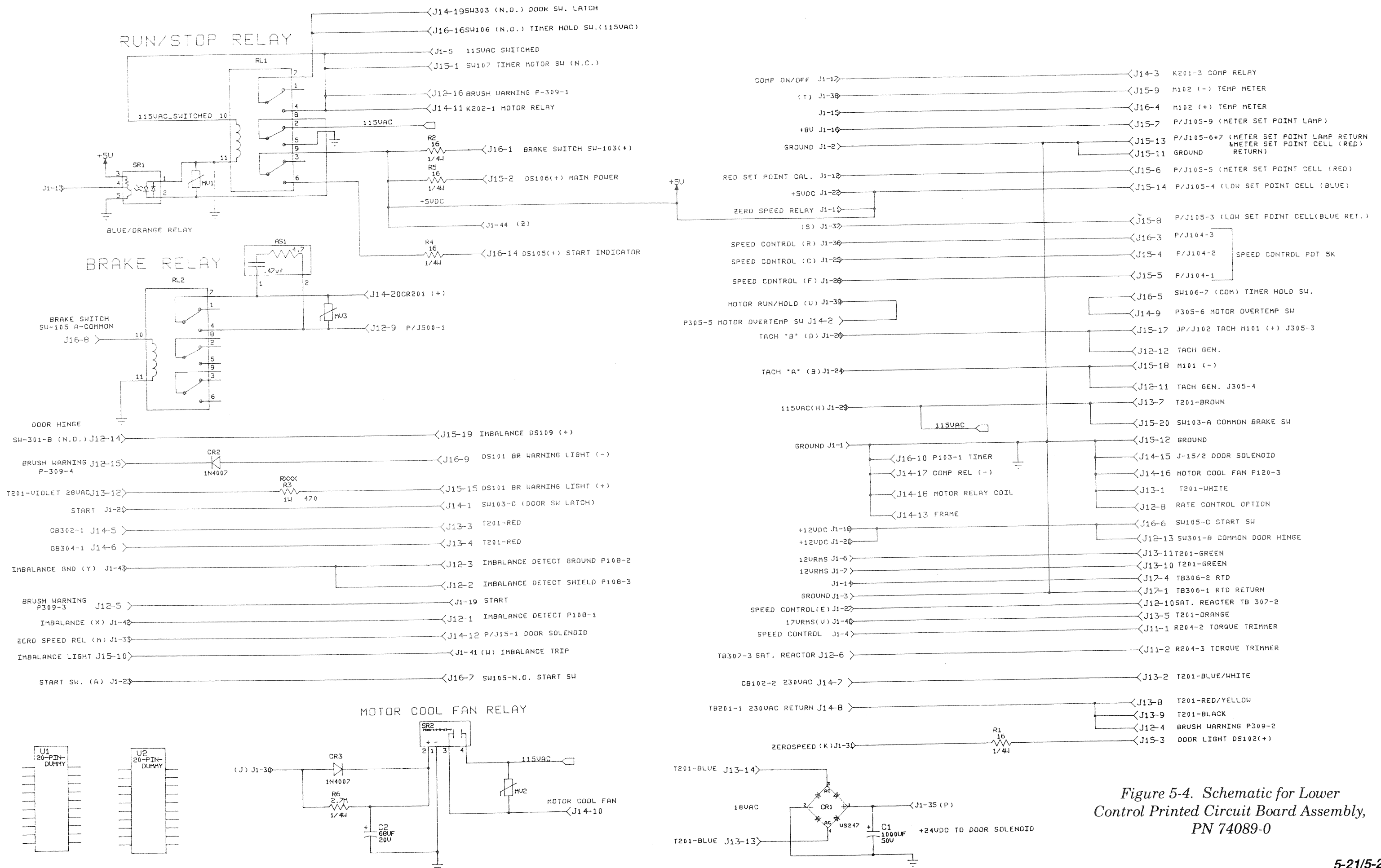

Figure 5-4. Schematic for Lower Control Printed Circuit Board Assembly, PN 74089-0

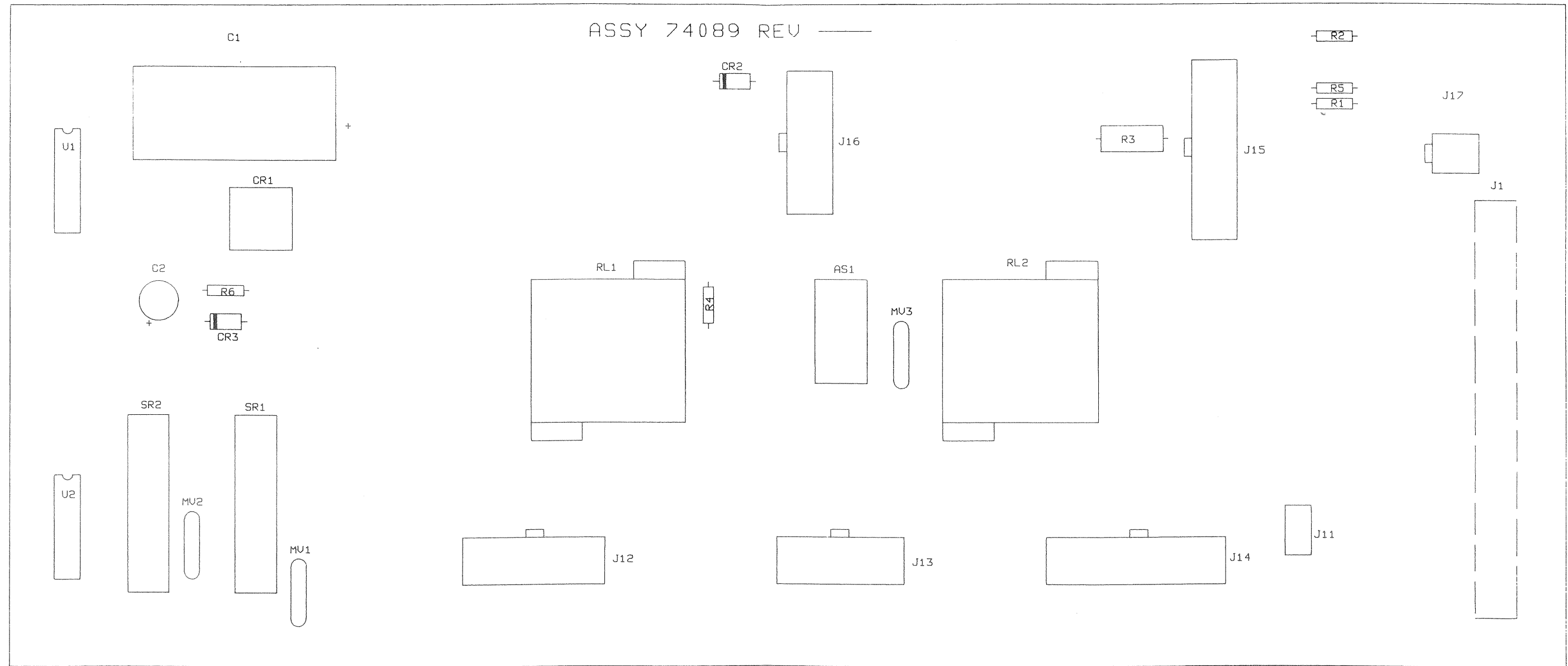

Figure 5-5. Component Location,
Lower Control Printed Circuit Board,
PN 74089-0

**Table 5-2. Component Description,
Lower Control Printed Circuit Board, PN 74089-0 74306**
(refer to figure 5-5)

Component	Description
AS1	Network Resistor Cap
C1	Capacitor, 1000 μ F, 20%, 50V
C2	Capacitor, Tantalum, 68 μ F, 20%, 20V
CR1	Bridge Rectifier
CR2, CR3	Diode
J1	Connector, 44-pin
J11	Connector, 2-Minifit
J12, J16	Connector, 16-Minifit
J13	Connector, 14-Minifit
J14, J15	Connector, 20-Minifit
J17	Connector, 4-Minifit
MV1, MV2, MV3	Varistor, 250V
R1, R2, R4, R5	Resistor, Carbon, 15 Ω , 5%, 1/4W
R3	Resistor, Carbon, 470 Ω , 5%, 1W
R6	Resistor, Carbon, 2.7M Ω , 5%, 1/4W
RL1, RL2	Socket, Relay
SR1	Relay
SR2	Relay, Solid State

Section 6: CALIBRATION

This section includes all of the necessary calibration procedures for the RC-5B PLUS centrifuge.

6-1. Precautions for Handling Printed Circuit Boards



CAUTION

Some printed circuit board components can be damaged by static voltage; therefore, it is important to use these precautions when handling printed circuit boards.

The printed circuit (P.C.) boards in this centrifuge consist of circuits that contain CMOS devices; as a result, they are especially susceptible to damage by electrostatic discharge (ESD). If you handle these boards, you must be familiar with generally accepted ESD handling procedures.

To avoid damaging static-sensitive electronic components, observe all of the following precautions when handling printed circuit boards and electronic components and assemblies:

- Wrap P.C. boards in a conductive plastic packing material, such as Velostat[®] by 3M Company, whenever they are shipped or stored.
- Always handle a printed circuit board by its corners only. Handle components by the cap edges or bodies.
- Cover all connectors with conductive plastic whenever a printed circuit board is out of the centrifuge.
- When handling unwrapped P.C. boards, electronic components, or electronic assemblies, use properly grounded electrostatic discharge protective devices (for example, wrist straps, heel straps, conductive mats).
- Place static-sensitive P.C. boards, electronic components, or electronic assemblies on properly grounded work surfaces or in containers designed to dissipate static charge. Touch the work surface before touching the electronic components.
- Install static-sensitive parts in the centrifuge or wrap them in protective packaging before removing your protective equipment.
- Keep the following items away from static-free work areas: soldering guns, food, hand cream, paper, nonconductive plastic, plastic foam, and cardboard.

**WARNING**

Untrained personnel must not attempt to perform calibrations. Critical adjustments that are in the vicinity of high voltage components create electrical hazards to personnel unfamiliar with SORVALL[®] systems, so as to restrict use of these procedures to only highly trained service technicians.

6-2. Calibration Sequence

Since some circuit functions are dependent on and interrelated with others, the calibration procedures must be performed in specific sequence. Table 6-1 contains columns entitled ITEM REPLACED, REPLACEMENT PARAGRAPH, and CALIBRATION SEQUENCE. The ITEM REPLACED column lists all parts requiring calibration due to replacement or aging. The REPLACEMENT PARAGRAPH column provides a cross-reference to specific paragraphs associated with troubleshooting or replacement procedures. The CALIBRATION SEQUENCE column provides sequential step references subordinate to paragraph 6-5 and denotes which calibration procedures must be performed for the listed part. The step references are sequential and are used only in a left-to-right numerical progression as shown.

6-3. Calibration Criteria & Adjustment Locations

Ambient room temperature must not exceed 25°C and should remain stable when performing the calibrations. Also, power supplied to the centrifuge must be stable and constant. Unless otherwise specified, all test points (TP) and potentiometer (R) adjustments are located on Controller Printed Circuit Board, PN 74095. Figure 6-1 locates these items. Tables 6-3 and 6-4 describe the test points and calibration for the Controller P.C. Board, PN 74095. 12987

6-4. Test Equipment Required

- Volt/Ohmmeter: Fluke 3060A or equivalent.
- Resistor, 149.79 ohm, 0.1%. Precision Resistor, 106.15 ohm, 0.1%.
- Ammeter (clamp-on type): Triplet Model 10 or equivalent.
- Portable Tachometer
- Thermometer: McAlaster No. 39682 (-35°C to -50°C) or equivalent.

6-5. Calibration Procedures

a. Speed Indicator M101 Zero Adjust

The meter pointer should indicate zero at zero rotor rpm.

1. Set the main circuit breaker to OFF.
2. While gently tapping face of indicator M101, turn the front access zero adjust clockwise until the pointer aligns with zero indication during the upswing.

b. Temperature Indicator M102 Zero Adjust

The temperature pointer (black) should indicate -20°C when the main circuit breaker is at OFF.

1. Set the main circuit breaker to OFF.
2. While gently tapping the face of M102, turn the front access zero adjust until the temperature pointer aligns with -20°C indication.

c. Speed Control Potentiometer R106

This is a mechanical alignment of SPEED selection for reference only.

1. Turn the SPEED control knob fully counterclockwise, then loosen the two knob setscrews.
2. Align the knob 0 (zero) indication with the SPEED indication and secure the two setscrews.

d. Source Power

This is a check of the main power to assure proper operation of centrifuge.

1. Check the source voltage.
2. The source voltage must be within 1.0% of the power rating specified on the back of the centrifuge.

e. Torque Trimmer Potentiometer R204

This component limits current drawn by the drive motor to govern rotor speed.

1. Install an SS-34 rotor and close the chamber door.
2. Set the SPEED control to 21 000 rpm.

4. Adjust the blue pointer exactly below the black pointer to activate the refrigeration system.
5. Position the clamp-on ammeter over the black or white heavy gauge wires coming from the main power switch.
6. After drive motor speed has stabilized and the compressor achieves stable operation, adjust potentiometer R204 for maximum rotor speed while not exceeding 30 A total current draw. Allow speed stabilization after adjustment then recheck the rotor speed and current draw.
7. Set the main circuit breaker to OFF, then remove the clamp-on ammeter.

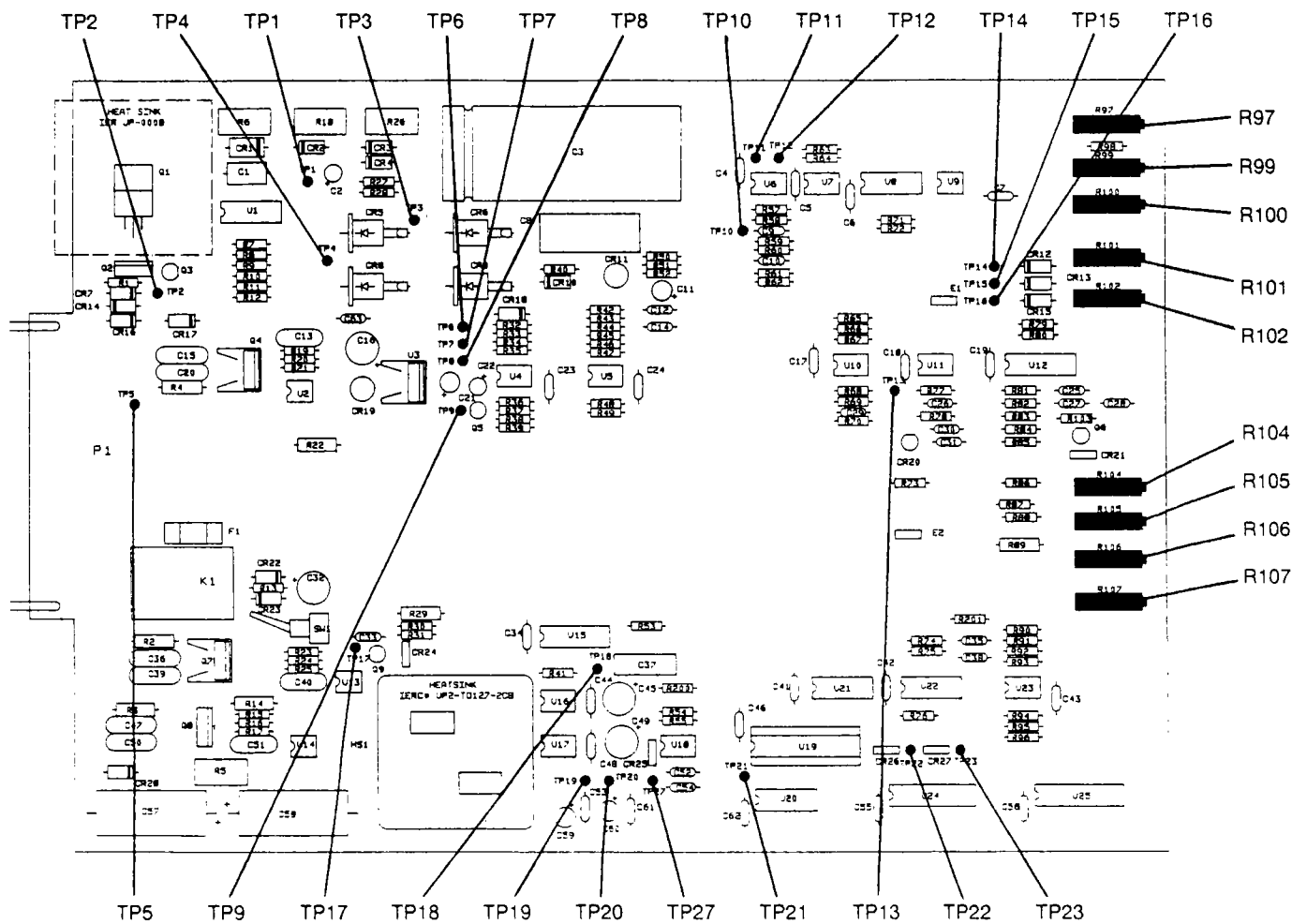

Figure 6-1. Test Point and Adjustment Locations for Controller P.C. Board Assembly, PN 74095 12987

Table 6-1. Calibration Sequence

Item Replaced	Calibration Sequence											
	Perform steps a through n in paragraph 6-5 in the sequence given											
	1	2	3	4	5	6	7	8	9	10	11	12
Tachometer Indicator M101	a	g										
Temperature Indicator M102	b	d	i	j								
Controller P.C. Board, PN 74095 ¹²⁹⁸⁷	a	d	f	h	c	g	b	i	j	k	l	
Speed Control R106	c											
Torque Trimmer R204	d	c										
Resistance Temperature Detector (RTD)	b	k										
Tachometer-Generator	g	f	h									
Tachometer Indicator Adjust R109	a	g										
Drive Motor	d	a	g	f	e	h						
Saturable Reactor	d	a	g	f	e	h						
Transformer T201	d											
Timer	m											
Gyro Drive Assembly	n											

f. Speed Control Low Speed Potentiometer (R99) and High Speed Potentiometer (R97) Set

This calibrates the speed control circuit for accurate control of rotor speed.

1. Install an SS-34 rotor, then close the chamber door.
2. Connect the portable tachometer to the tachometer jacks on the front panel.
3. Set the SPEED control to 1000 rpm.

4. Place the system in the RUN mode.
5. Adjust potentiometer R99 for a tachometer indication of 1000 rpm.
6. Set the SPEED control to 20 000 rpm.
7. Adjust potentiometer R97 for a tachometer indication of 20 000 rpm. If full counterclockwise adjustment does not result in 20 000 rpm indication, adjust torque trimmer potentiometer R204 until 20 000 rpm is indicated.

g. Speed Indicator M101 Tracking Adjustment Potentiometer (R109)

This procedure adjusts the full range of speed indication.

1. Install an SS-34 rotor and close the chamber door.
2. Place the system in the RUN mode. Connect the tachometer to the tachometer jacks on the front panel.
3. Operate alternately at 1000 rpm and 20 000 rpm, then adjust potentiometer R109 until the error at both speeds is minimized.

h. Overspeed Detector Potentiometer (R100)

This procedure adjusts the overspeed detection circuitry for RUN mode disable at 22 000 rpm \pm 200 rpm.

1. Install an SS-34 rotor and close the chamber door.
2. Adjust potentiometer R100 to disable the RUN mode when the motor speed is at 22 000 rpm \pm 200 rpm.

i. Temperature Indicator M102 Deflection Adjust -20°C Potentiometer (R106) and +40°C Potentiometer (R105)

This procedure adjusts M102 for zero and full scale indications.

1. Set the circuit breaker to OFF.
2. Place the centrifuge system in the HOLD mode.
3. Adjust potentiometer R105 fully counterclockwise.
4. Referring to figure 6-2, place the 106.15 ohm precision resistor in the circuit.

5. Adjust potentiometer R106 for a -20°C indication. Remove the 106.15 ohm resistor.
6. Referring to figure 6-2, place the 149.79 ohm precision resistor in the circuit.
7. Adjust potentiometer R105 for a $+40^{\circ}\text{C}$ indication .
8. Repeat steps 4 through 7 until -20°C and $+40^{\circ}\text{C}$ indications are obtained.
9. Set the main circuit breaker to OFF.
10. Remove the precision resistor and reconnect the original circuit as shown in figure 6-2.

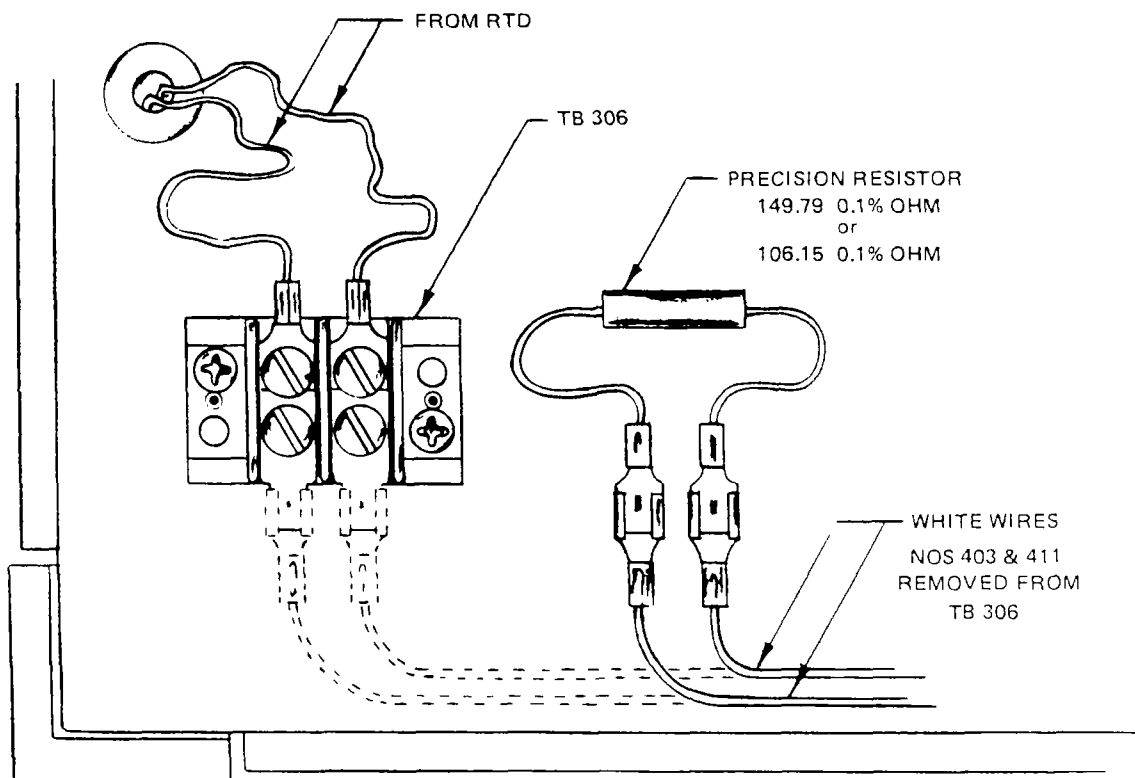

7 79
RCS 111

Figure 6-2. Test Setup for Temperature Meter Deflection Adjustment

j. Rotor Speed Temperature Differential Set-Point Calibration at 20 000 rpm (R106)

This procedure compensates for the temperature differential between the rotor and the chamber at 20 000 rpm.

1. Install an SS-34 rotor with two tubes balanced and half full of alcohol or other antifreeze liquid precooled to +2°C.
2. Set the RUN mode set-pointer to -3°C.
3. Operate in the RUN mode at 5000 rpm until the temperature indication stabilizes at -3°C, and then at 20 000 rpm for 45 minutes. With the brake on, allow the rotor to decelerate to a complete stop. Then, record the temperature.
4. At zero rpm, quickly place a thermometer into one tube for three minutes, then quickly into the second tube for two minutes. The desired temperature of the material in the rotor is +2°C with the pointer set at -3°C.
5. Adjust potentiometer R106 until the -3°C set-pointer indication is 5°C colder than the temperature recorded in step 4 — clockwise rotation will increase the rotor temperature while moving the temperature pointer downward.
6. Repeat steps 2 through 5 until -3°C set-pointer is 5°C below the temperature recorded in step 4.

k. Temperature Control Set-Points Potentiometer (R107 and R104)

This procedure establishes the RUN and HOLD mode compressor set points.

1. Set the main circuit breaker to ON.
2. Install an SS-34 rotor and close the chamber door.
3. Set the RUN mode set point to 5°C below indicated temperature.
4. Set the HOLD mode set point to 5°C above indicated temperature.
5. Connect the dc voltmeter to TP27 (-) and TP22 (+). The meter indication should be greater than 4.5 Vdc.

6. Move the HOLD set-pointer toward the back temperature indicator pointer until the HOLD pointer is exactly over the black temperature indicator pointer. The voltage should switch to lower than 1.0 Vdc.
7. If the voltage change occurs above or below the set-pointer, align the set-pointer with the black indicator and adjust potentiometer R107 accordingly.
8. Set the SPEED dial to 1000 rpm.
9. Make sure the rotor is properly installed and the chamber door closed and latched.
10. Set the HOLD mode set point to 5°C above indicated temperature.
11. Set the RUN mode set point to 5°C below indicated temperature.
12. Connect a dc voltmeter to TP27 (-) and TP23 (+).
13. Place the system in the RUN mode. The meter indication should be less than 1.0 V dc.
14. Move the RUN set point towards the black temperature indicator pointer until the pointer is completely aligned with the black temperature indicator pointer. The voltage should switch to greater than +4.5 Vdc.
15. If the voltage change occurs above or below the set point, align the set point with the black indicator, then adjust potentiometer R104 accordingly.

1. Overtemperature Detection Set-Pointer (R102)

This procedure adjusts the overtemperature set point to inhibit, or disable the operation of, the RUN mode.

1. Set the main circuit breaker to ON.
2. Set the RUN mode set-pointer at 10°C to 15°C below indicated temperature.
3. Set the HOLD mode set point to coincide with the indicated temperature.
4. Be sure that rotor is secured and the chamber door is latched.
5. Set the SPEED control to 0 rpm.

6. Place the system in the RUN mode. Press the START switch.
7. Slowly decrease the TEMPERATURE set point to 3°C below the indicated temperature. The system should transfer to the HOLD mode — the START switch should go OFF.

If these conditions are not obtained, adjust R102 accordingly.

m. Timer Control Knob and Switches S106 & S107 Adjustment

This procedure adjusts the mechanical adjustment of control knob and switches.

1. Set the main circuit breaker to ON.
2. Make certain that the rotor is secured and the chamber door latched.
3. Set the SPEED control to 1000 rpm.
4. Press and hold the START switch, then rotate the timer control shaft counterclockwise until the RUN mode stays ON, then release the START switch.
5. Rotate the timer control shaft counterclockwise until the RUN to HOLD mode transition occurs.
6. Align and secure the timer control knob STOP position with the console vertical mark.

n. Imbalance Detector Calibration (R101)

Each rotor has a predetermined maximum weight in grams of imbalance that when detected causes the IMBALANCE light to come on and the centrifuge to shut down.

NOTE For proper imbalance detector calibration, the centrifuge must be level and evenly supported on its casters and two front locking stabilizers.

1. Remove the six (6) mounting screws that secure the front control panel to the console. Leave the panel in place.
2. On the Controller Printed Circuit (P.C.) Board, adjust R101 until +3.0 Vdc is achieved between pin 2 of TP27 (ground) or left side of R78 (12 Kohms) and TP27 (ground).

3. Set up the centrifuge as follows:
 - a. Set the SPEED dial to 2000.
 - b. Set TEMPERATURE needles to 4°C.
 - c. Set TIME dial to HOLD.
 - d. Set BRAKE switch to ON (the light will be on).
 - e. Install a rotor in centrifuge, precool if necessary, refer to paragraph 3-7.

NOTE For proper calibration of the imbalance detector the TEMPERATURE meter must show 4°C. Precool the rotor, if necessary, refer to paragraph 3-7.

The imbalance detector calibration is most easily accomplished using an SS-34 rotor. When set with the minimum and maximum weights specified for an SS-34 rotor, all other rotors should meet the specification for minimum and maximum weight limits as specified in Table 6-2. If an SS-34 rotor is not available, check each rotor individually with the weights specified in Table 6-2.



CAUTION

When the maximum weight is in the rotor compartment, the IMBALANCE light must come on by 1200 rpm. If it does not, press the STOP switch to end the run. Adjust R101 counterclockwise before doing another run.

Table 6-2. Imbalance Detection Threshold

Rotor (Unloaded)	Imbalance Threshold	
	Minimum Weight (grams)	Maximum Weight (grams)
SS-34	20 g	60 g
SA-600	20 g	60 g
GSA	60 g	120 g

- f. Place the minimum weight in the bottom of one of the rotor tube compartments (refer to Table 6-2). Secure the lid on the rotor and close the centrifuge chamber door.

NOTE One U.S. nickel is equal to approximately 5 grams.

Two U.S. quarters and one U.S. penny is equal to 15 grams.

Three U.S. quarters and one U.S. penny is equal to 20 grams.

- g. When the displayed temperature is 4°C, press the START switch.

4. Observe the IMBALANCE light as the rotor accelerates to 2000 rpm.

If the minimum weight causes the IMBALANCE light to come on and the centrifuge to shut off, the detector is too sensitive.

- a. Adjust R101, on the Controller P.C. Board, clockwise to decrease imbalance sensitivity.
- b. Press the START switch.
- c. Repeat step 3 on previous page.

If the minimum weight does not cause the IMBALANCE light to come on:

- a. Press the STOP switch.
- b. Leave the rotor on the drive spindle. Remove the minimum weight from the tube compartment and place it in the opposite tube compartment.
- c. Press the START switch.
- d. Repeat step 3 on the previous page.

If the minimum weight in the opposite tube compartment causes the IMBALANCE light to come on and the centrifuge to shut off, the detector is too sensitive.

- a. Adjust R101, on the Controller P. C. Board, clockwise to decrease imbalance sensitivity.
- b. Press the START switch.
- c. Repeat step 3 for minimum weight in opposite tube compartment.

If the minimum weight in the opposite tube compartment does not cause the IMBALANCE light to come on:

- a. Press the STOP switch.
- b. Leave the rotor on the drive spindle. Remove the minimum weight from tube compartment B.
- c. Go to step 5.

5. Install the maximum weight, 20 grams, in the bottom of one of the rotor tube compartments. Secure the lid on the rotor and close the centrifuge chamber door.

6. Press the START switch.
7. Observe the IMBALANCE light as the rotor accelerates to 2000 rpm.

If the maximum weight does not cause the IMBALANCE light to come on, the detector is not sensitive enough.

- a. Press the STOP switch.
- b. Adjust R101, on the Controller P.C. Board, counterclockwise to increase imbalance sensitivity.
- c. Press the START switch.
- d. Repeat step 7.

If the maximum weight causes the IMBALANCE light to come on and the centrifuge to shut off:

- a. Leave the rotor on the drive spindle. Remove the maximum weight from the tube compartment and place it in the opposite tube compartment.
- b. Press the START switch.
- c. Repeat step 7.

If the maximum weight in opposite tube compartment does not cause the IMBALANCE light to come on, the detector is not sensitive enough.

- a. Press the STOP switch.
- b. Adjust R101, on the Controller P.C. Board, counterclockwise to increase imbalance sensitivity.
- c. Press the START switch.
- d. Repeat step 7 for maximum weight in opposite tube compartment.

If the maximum weight in opposite tube compartment causes the IMBALANCE light to come on and the centrifuge to shut off:

- a. Leave the rotor on the drive spindle. Remove the maximum weight from tube compartment.
- b. Go to step 8.

8. Recheck imbalance detector sensitivity with minimum weight.
9. Reinstall the front control panel with the six (6) mounting screws.
10. Remove the rotor from the centrifuge.
11. Set the main circuit breaker, POWER switch, to OFF.

Table 6-3. Test Point Descriptions for the Controller P.C. Board, PN 74095 12987

Test Point	Description
TP1	SPEED CONTROL 'IN'
TP2	SPEED CONTROL 'OUT'
TP3	TACHOMETER VOLTAGE (B)
TP4	TACHOMETER VOLTAGE (A)
TP5	REMOTE START (+12 Vdc-Activation)
TP6	ZERO SPEED REF
TP7	ZERO SPEED SIGNAL
TP8	ANALOG GROUND (+12 V Isolated Power Supply)
TP9	ZERO SPEED RELAY CONTROL
TP10	OVERSPEED "IN"
TP11	+12Vdc ISOLATED
TP12	OVERSPEED LEVEL ADJUST VOLTAGE
TP13	IMBALANCE "IN"
TP14	OVERSPEED (FAULT)
TP15	OVERTEMP (FAULT)
TP16	IMBALANCE (FAULT)
TP17	COMPRESSOR "ON" SIGNAL
TP18	RESET SIGNAL (PAL)
TP19	+12 Vdc DIGITAL
TP20	+5 Vdc DIGITAL
TP21	ONE SECOND PULSE "OUT"
TP22	HOLD SWITCH POINT (ORANGE)
TP23	RUN SWITCH POINT (BLUE)
TP27	GROUND

NOTE There are no test points given on the Controller P.C. Board for TP24, TP25, and TP26.

**Table 6-4. Potentiometer Adjustment for the
Controller P.C. Board, PN 74095 12987**

R97	Speed Control High rpm setting 20 000 rpm.
R99	Speed Control Low rpm setting 1000 rpm.
R100	Overspeed Detector. Adjust to cut power to centrifuge drive when speed exceeds 21 000 rpm.
R101	Imbalance Detection Threshold Setting
*R102	Temperature Control Overtemperature Detector. Adjust to cut power to centrifuge drive when temperature indicating needle reaches 3°C higher than red (hold) pointer setting.
*R104	Temperature Control Blue Pointer (run). With rotor installed, run centrifuge at approximately 1000 rpm. Adjust to turn the compressor off when temperature indicating needle meets Run Temperature Set Point.
*R105	Temperature Control Indicating Needle +40 Set Point.
*R106	Temperature Control Indicating Needle -20 Set Point.
NOTE Use temperature calibrating test set when adjusting R40 and R41.	
*R107	Temperature Control Orange Pointer (hold). Adjust to turn compressor on when temperature indicating needle meets Hold Temperature Set Point.

*When adjusting potentiometers R102, R104, R105, P106, and R107, disconnect one compressor lead from relay K201 to prevent compressor from cycling on and off. Hold cycle has a two minute time delay after each 15 second cycle. This time delay may be avoided when calibrating R107 by placing one probe of VOM meter on collector lead of Q15 and other probe on TPl.

Meter will read 5 Vdc when compressor is in off cycle and will read 0 volts when compressor is in run cycle. Temperature calibrating test set may also be used on adjustments R102, R104, and R107 using variable setting.

Section 7: ILLUSTRATED PARTS

This section provides illustrations of RC-5B PLUS assemblies and each illustration is keyed by item numbers to an accompanying parts list. The parts lists provide the part numbers and descriptions of each item that is called out on the illustrations. When ordering replacement parts, specify the part number and description, and the serial number of the centrifuge.

NOTE Tables throughout this section contain part numbers valid at the time of printing. All part numbers are subject to change without notice. Part numbers in BOLD type are currently stocked at our parts depot and are routinely available. Other parts listed will be provided on a *best effort* basis.

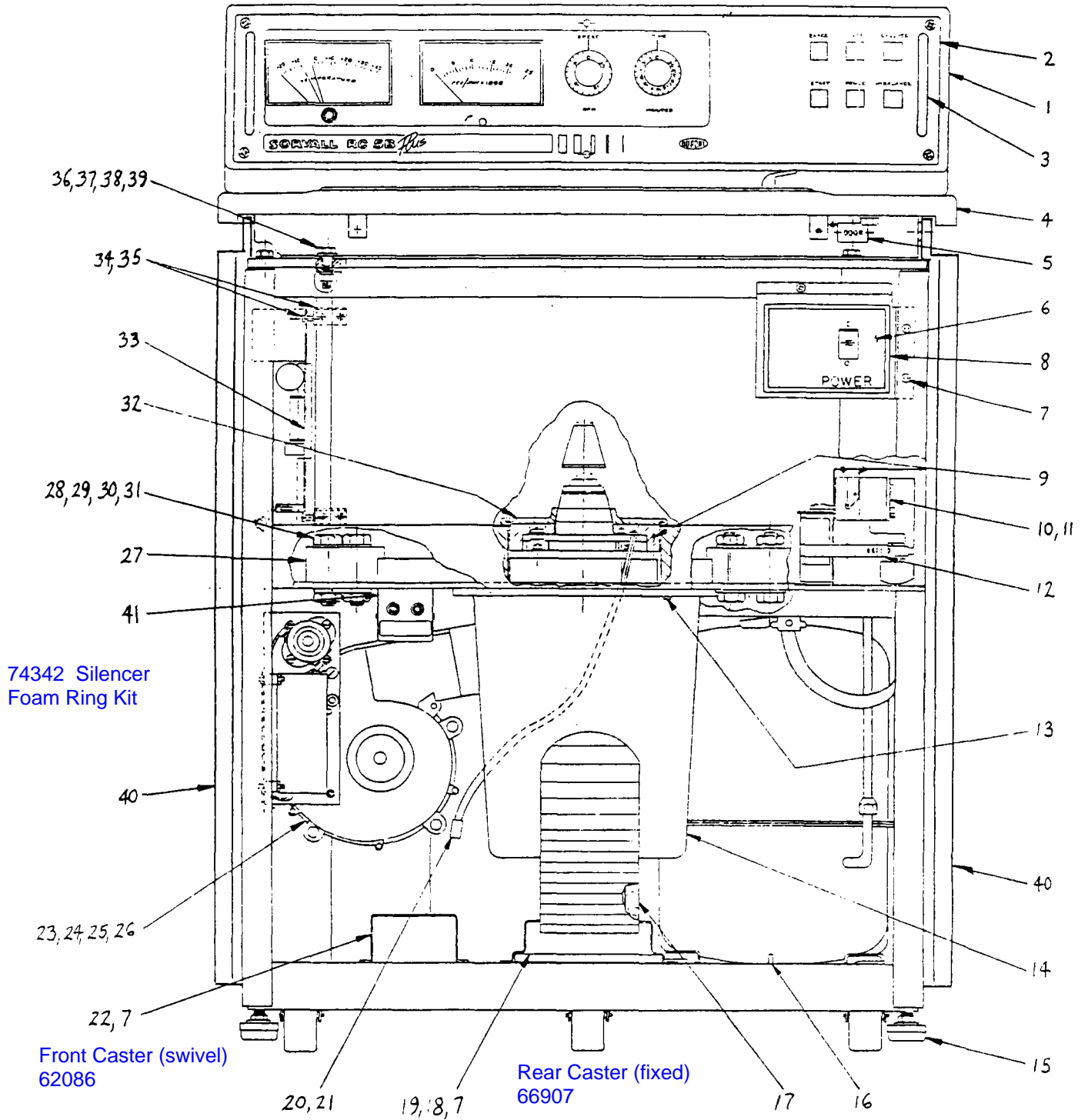

Figure 7-1. RC-5B PLUS Assembly, Front View

Table 7-1. RC-5B PLUS Assembly, Front View

Item No.	Description	Part No.
1	RC-5B PLUS Console Assembly	74027
2	Front Console Panel Assembly	74040
3	Front Console Panel Handle	55531
4	Deck Assembly	74025
5	Door Button	50689
6	RC-5B PLUS Panel Assembly, Main Breaker	74116
7	Screw, Pan Head with Lockwasher, Phillips, SST, #8-32 x 3/8 long	91420
8	Bezel, Circuit Breaker Panel	55508
9	Foam Insulating Disc	50415
10	Relay, Potential	91489
11	Screw, Pan Head with Lockwasher, Phillips, SST, #8-32 x 1/4 long	62828
12	Bracket, Adjustable Band	91057
13	Cap Screw, Hex Head with Lockwasher, SST, 1/4-20 x 1 long	91455
14	Silencer Assembly	74074
15	Leveling Pad	60619
16	Cap Screw, Socket Head-Hex, STL, 1/4-20 x 1-1/4 long	62844
17	Exhaust Duct Assembly	74035
18	Filter Assembly (includes foam strips)	74037
19	Filter Holder	74038
20	Imbalance Detector Harness Assembly	50778
21	Connector	68683
22	Bracket	56058
23	Blower Motor Assembly	74119
24	Bracket, Blower Motor	74047
25	Screw, indented Hex with Lockwasher, STL, 1/4-20 x 1/2 long	66543
26	Nut, Hex with Lockwasher, #8-32	91482
27	Hold Down Block (Guard to Base)	20839
28	Bolt, Hex Head, Grade 5 STL, Cad Pl, 5/8-11 x 1-1/2 long	65646
29	Flat Washer, 5/8. STL, Cad Pl, 1-1/4 O.D. x 41/64 I.D. x 1/16 thick	65647
30	Split Lockwasher, 5/8, STL, Cad Pl	65648
31	Nut, Hex, Jam, Grade 5, STL, 5/8-11	64784
32	Gyro Cover Seal	50414
33	Control Printed Circuit Board Assembly	12987 74095
34	Bracket, Control P.C. Board	20137
35	Screw, Pan Head with Lockwasher, Phillips, STL Zinc Plated, 6-32 x 1/2	91403
36	Nut, Hex, STL, Zinc Plated, 3/8-16 x 21/64 thick	91385
37	Split Lockwasher, STL, Zinc Plated, 3/8 x 0.070 thick	91380
38	Flat Washer, 13/32 I.D. x 13/16 O.D. x 1/16 thick	61627
39	Cap Screw, Hex Head, STL, Zinc Plated, 3/8-16 x 1-1/2 long	91450
40	Panel Assembly, Right Side and Left Side	74111
41	Brush Warning Assembly	20747

RC-5B+/5C+ Preventative Maintenance Kit

12011

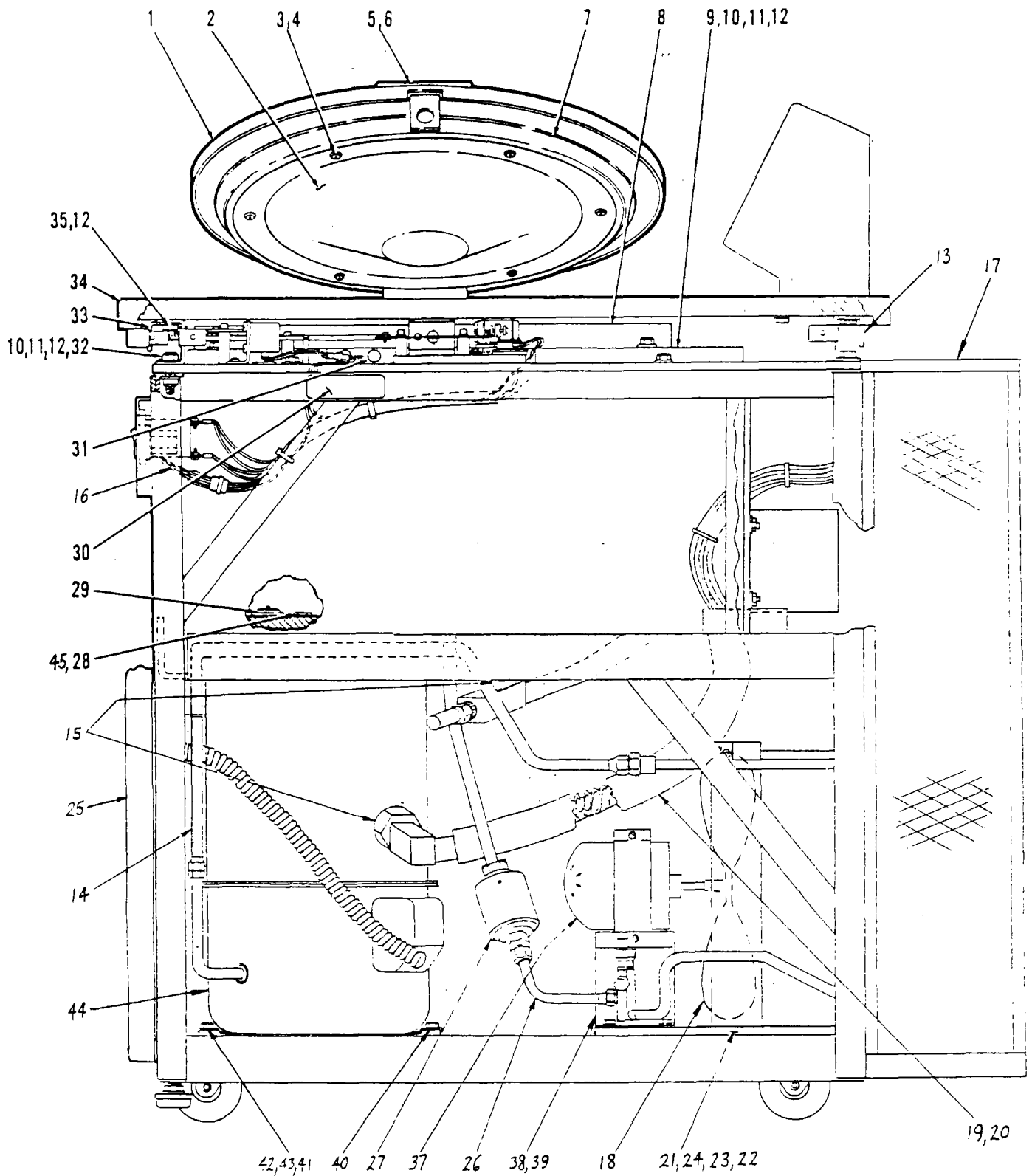

Figure 7-2. RC-5B PLUS Assembly, Right View

Table 7-2. RC-5B PLUS Assembly, Right View

Item No.	Description	Part No.
1	Door Assembly	74033
2	Diffuser Assembly	74034
3	Washer, Finishing, SST, #10	60683
4	Screw, Wood, Oval Head, Phillips, SST, #19 x 1-1/4 long	65676
5	Door Handle	74028
6	Cap Screw, Flat Head, Socket Hex, Black Oxide, #8-32 x 1 long	66982
7	Upper Door Seal	50473
8	Shroud	50094
9	Evaporator Top Plate	50610
10	Cap Screw, Hex Head, STL, 3/8-16 x 1-1/2 long	91450
11	Flat Washer, 3/8, STL, Cad Pl, 13/32 I.D. x 13/16 O.D. x 1/16 thick	61627
12	Split Lockwasher, 3/8, STL, STL, Zinc Plated	91380
13	Top Deck Support Assembly, Rear	50616
14	Tube Assembly (Compressor to Condenser)	74115
15	Seal, Teflon® Fiber	61768
16	Harness Assembly, Main Breaker	74131
17	Backpack Assembly	74316 74048
18	Fan Blade	91362
19	Suction Tube Assembly	74068
20	Suction Line Insulation (5-1/2 inches)	20588
21	Condensing Unit Assembly	74081
22	Flat Washer, 1/4, STL, Zinc Pl, 0.281 I.D. x 0.734 O.D. x 0.063 thick	91366
23	Split Lockwasher, SST, 1/4	63019
24	Cap Screw, Hex Head, STL, 1/4-20 x 1-1/2 long	64281
25	Front Panel Assembly with Insulation	74112
26	Tube Assembly (Valve to Filter Dryer)	74114
27	Filter Dryer	91470
28	Plug, Connector Body, Nylon	66577
29	Air Temp Sensor Assembly	20992
30	Label, High Voltage	61223
31	Cork, #4	66633
32	Nut, Hex, STL, Zinc Plated, 3/8-16	91385
33	Top Deck Support Assembly, Front	50430
34	Deck Assembly	74025
35	Screw, Hex Head, 3/8-16 X 3/4 long, STL, Cad Pl	64743
36	KSB Plug, Outer (Not Shown)	20972
37	Condenser Motor Fan	91392
38	Bracket, Condenser Motor Fan	56277 74056
39	Screw, Indented Hex with Lockwasher, STL, 1/4-20 x 1/2 long	66543
40	Screw, Indented Hex with Lockwasher, STL, 5/16-18 x 1/4 long	91369
41	Grommet, Compressor	91471
42	Screw, Indented with Lockwasher, STL, 5/16-18 x 1-3/4 long	66526
43	Sleeve, Compressor	91472
44	Compressor	91386
45	Flatwasher, 0.304 O.D. x 0.169 I.D.	63085

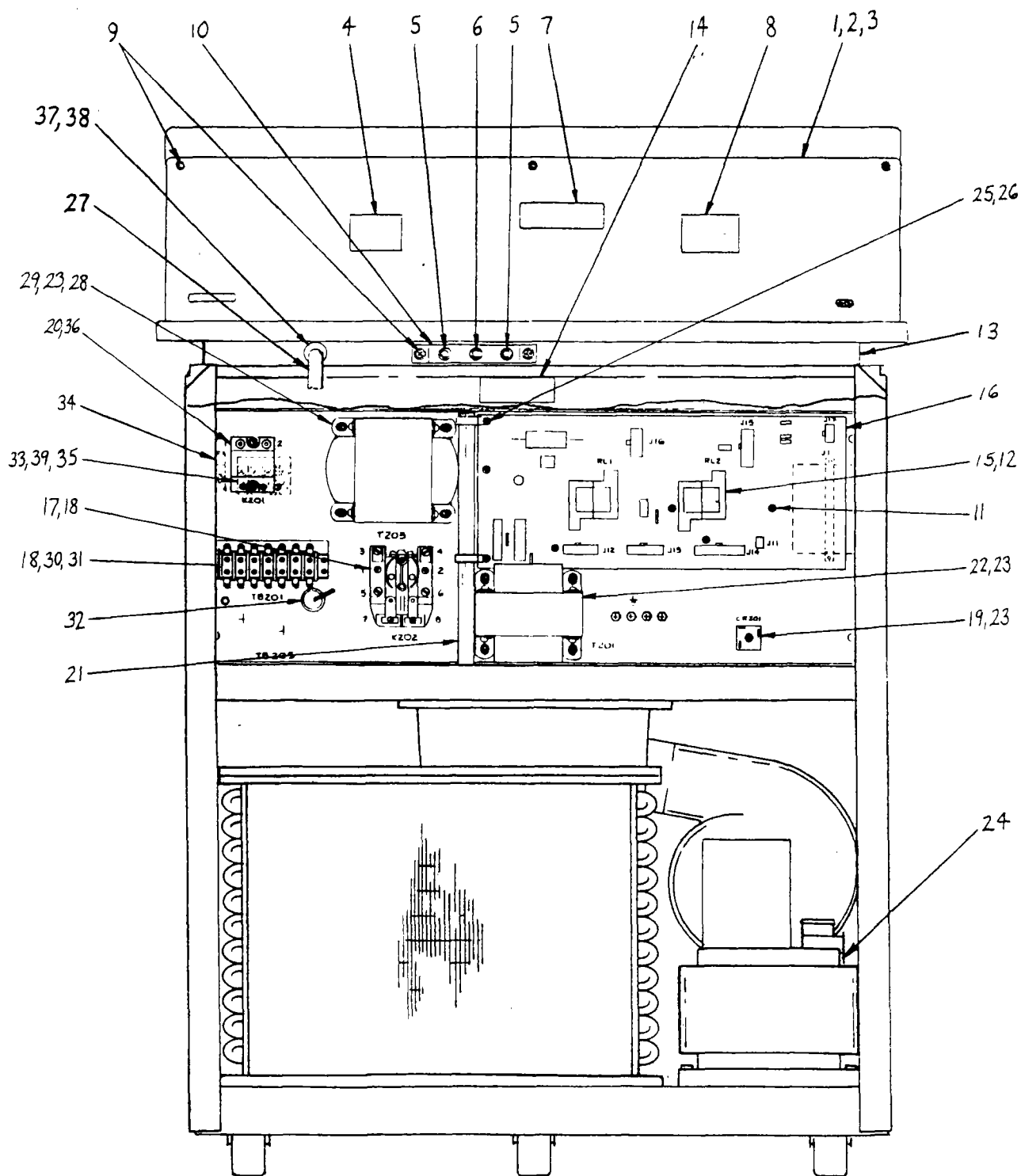

Figure 7-3. RC-5B PLUS Assembly, Rear View

Table 7-3. RC-5B PLUS Assembly, Rear View

Item No.	Description	Part No.
1	Console Backplate	74026
2	Cap Screw, Socket Head, STL, 1/4-20 x 3/4 long	91452
3	Lockwasher, External Tooth, SST, #1/4	63937
4	Nameplate	74120
5	Circuit Breaker, 5 Amp, 250 Vac	68716
6	Circuit Breaker, 3 Amp, 250 Vac	66759
7	Label, WARNING	68868
8	Label, CAUTION	67369
9	Screw, Pan Head with lockwasher, Phillips, SST, 8-32 x 3/8 long	91420
10	Breaker Bracket	50624
11	Screw, Pan Head, Phillips with External Tooth Washer, 6-32 x 1/4	91494
12	Relay, 3 PDT, 28 Vdc/115 ac, 10 Amp	91777
13	Support Assembly, Top Deck (Rear)	50616
14	Label, Danger, High Voltage	61223
15	Clip, Hold down	91496
16	Lower Control Panel P.C. Assembly	-74306 74089 74178
17	Relay, Power, Heavy Duty, 120 V	91351
18	Screw, Pan Head, Phillips, STL, Zinc Pl, 8-32 x 3/4 long	91481
19	Brake Rectifier	923627
20	Screw, Pan Head with lockwasher, SST, Zinc Pl, 8-32 x 1/4 long	91493
21	Main Harness Assembly	74134
22	Transformer Assembly	74073
23	Nut, Hex with Lockwasher, SST, #10-32	91410
24	Reactor Assembly	74075
25	Nylon Cable Tie Bar Lock (for Main Harness Assembly)	61518
26	Screw, Pan Head with Lockwasher, 6-32 x 1/2 long	91456
27	Power Cord	64065
28	Transformer Assembly	After 7/1/02 new transformer #76522 74563
29	Flat Washer, SST, #10	61652
30	Terminal Block, Barrier Type, 30 Amp Special	65997
31	Insulator, Terminal Block	66112
32	Grommet, 3/4 I.D. x 1-1/8 O.D. x 1/4 thick	62926
33	Terminal Strip, 4 Pole, 40 Amp, 380/450V	67415
34	Connector, Cable, #14-6 AWG Range, #10 MTG	65699
35	Insulator, Terminal Block	50352
36	Relay, Solid State, 3-28 Vdc	68794
37	Strain Relief	68037
38	Nut for Strain Relief	68038
39	Nut, Hex with lockwasher, SST, #6-32	91445

Line Filter

92005

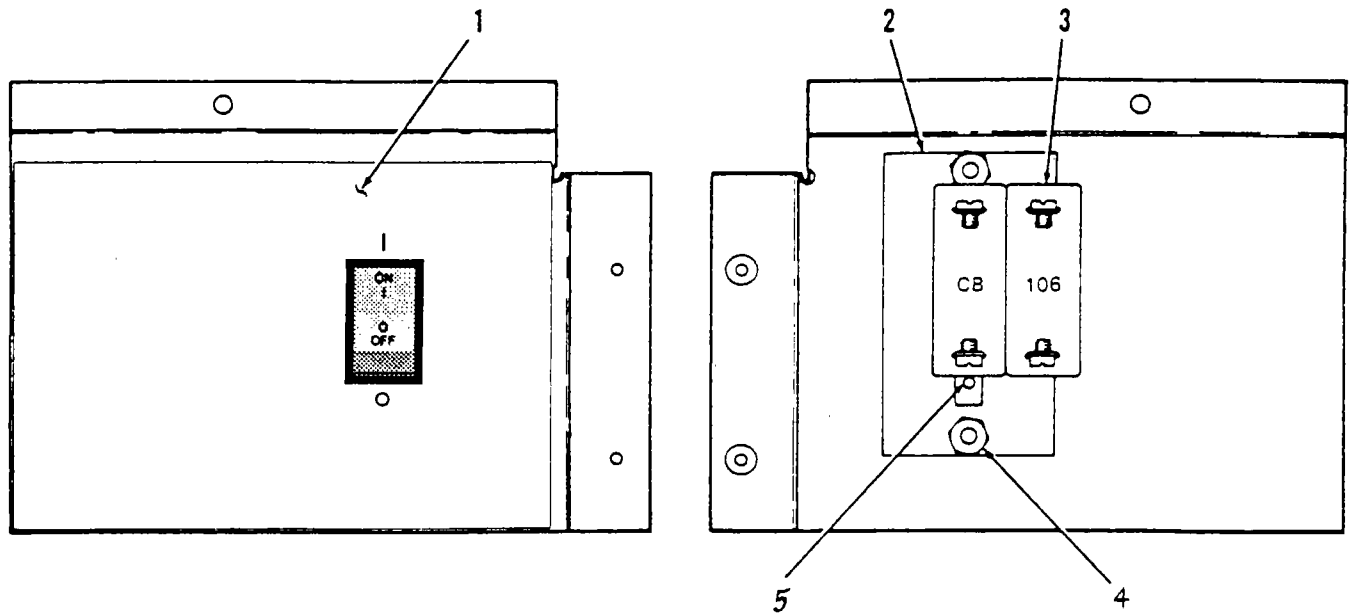

Figure 7-4. Panel Assembly, Main Breaker

Table 7-4. Panel Assembly, Main Breaker

Item No.	Description	Part No.
—	Panel Assembly, Main Breaker	74116
1	Overlay, Panel	74021
2	Plate, Mounting, Circuit Protector	50097
3	Circuit Protector, Two Pole, 30 amp	91476
4	Hex Nut with Lockwasher, SST, #10-32	91410
5	Screw, Flat Head, Slotted, SST, UNC, #6-32 x 1/4 long	60674

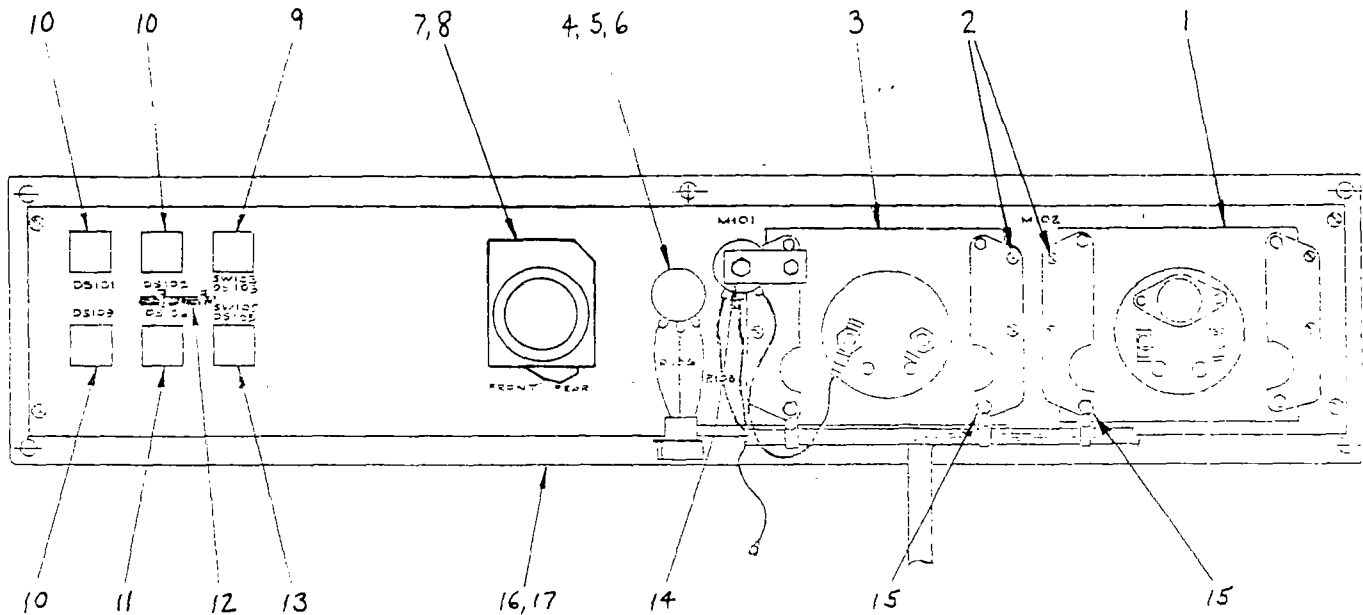

Figure 7-5. RC-5B PLUS Front Console Panel Assembly (Rear View)

Table 7-5. RC-5B PLUS Front Console Panel Assembly

Item No.	Description	Part No.
—	Front Console Panel Assembly	74040
1	Temperature Meter, -20°C to +40°C	90794
2	Screw, Pan Head with lockwasher, Phillips, STL, #6-32 x 3/8 long	91417
3	Speed Meter, rpm	66639
4	Potentiometer	20855
5	Spacer	04232
6	Knob, Speed Control	50134
7	Timer, 60 Hz	20868
8	Timer, 50 Hz	20867
8	Knob, Timer, 120 minute	50135
9	Switch, Pushbutton Assembly	74125
10	Indicator, Lighted Assembly, White	74122
11	Indicator, Lighted Assembly, Red	74124
12	Harness Assembly, Console	74041
13	Switch, Pushbutton Assembly, MOM	74123
14	Bracket, Potentiometer	20727
15	Nut, Hex, SST, 6-32	91445
16	Front Panel Overlay	74040
17	Front Panel Console	74071
—	Front Console Panel Handle (Not Shown)	55531
—	Bezel, Meter (Not Shown)	51242

LED Lamp

74179

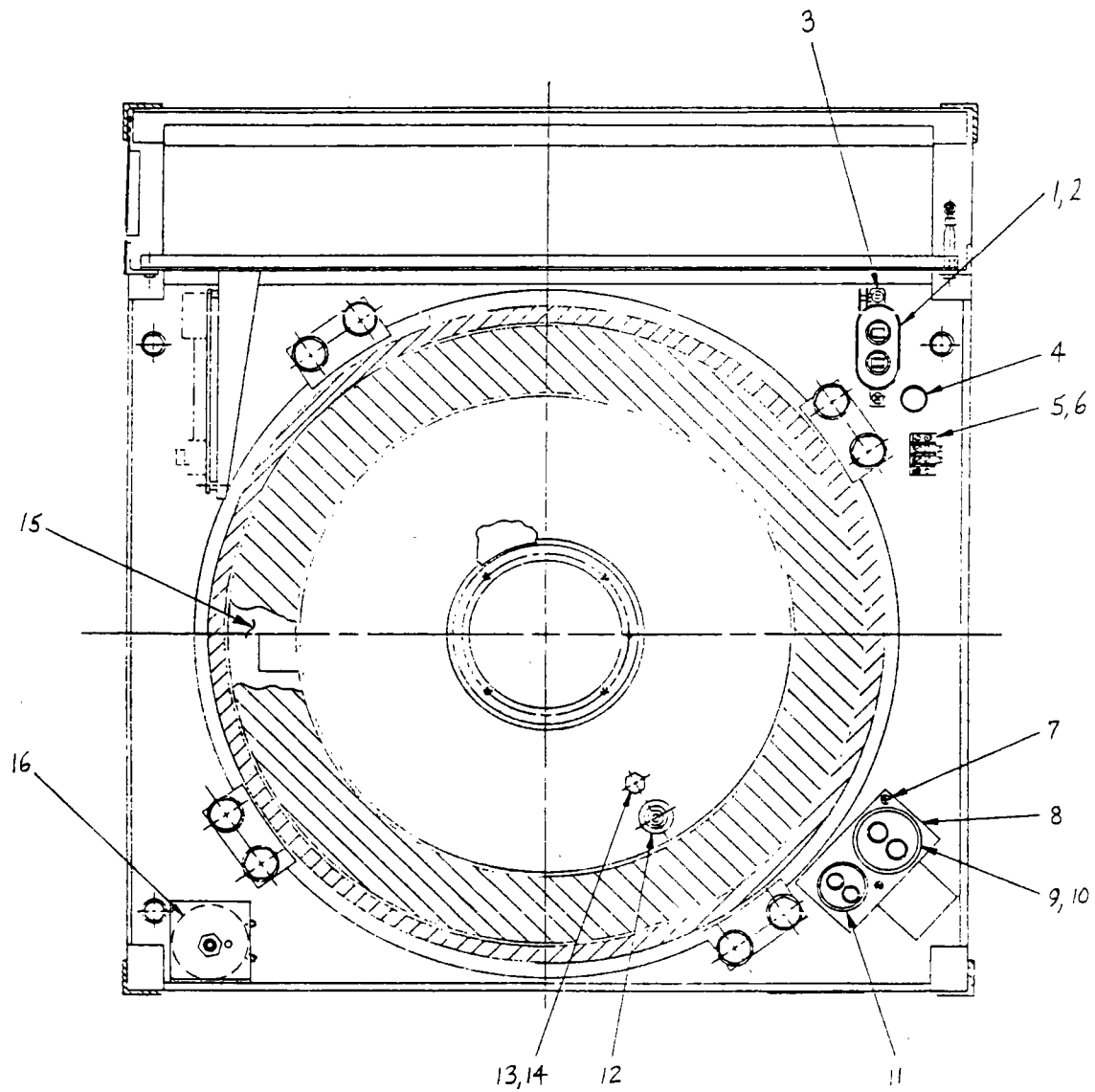

Figure 7-6. RC-5B PLUS Evaporator Assembly, Top View

Table 7-6. RC-5B PLUS Evaporator Assembly, Top View

Item No.	Description	Part No.
1	Capacitor, Motor Run, 20 μ F	66961
2	Bracket, Capacitor, Universal Wrap	66957
3	Screw, Pan Head with Lockwasher, Phillips, SST, 8-32 x 3/8 long	91420
4	Bushing, Snap-in	91430
5	Terminal Block, Barrier Type, 2 Terminal, 15 amp	64723
6	Screw, Pan Head with Lockwasher, SST, UNC, 6-32 x 3/4 long	91456
7	Screw, Pan Head with Lockwasher, SST, 10-32 x 1/2 long	91405
8	Bracket, Capacitor	76262
9	Capacitor, Start 176-216 μ F, 330 V, 15 K Ω	91475
10	Jumper Assembly	74144
11	Capacitor, Run, 25 μ F, 370 V	91474
12	Air Temperature Sensor Assembly	20992
13	Plug, Connector Body, Nylon	66577
14	Flatwasher, 0.304 O.D. x 0.169 I.D.	63085
15	Insulation, Evaporator	20094
16	Torque Trimmer Assembly	74133

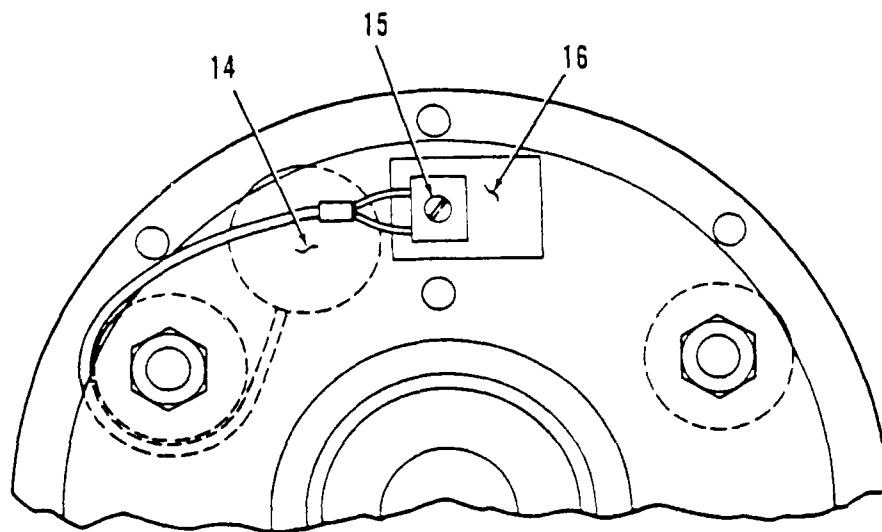
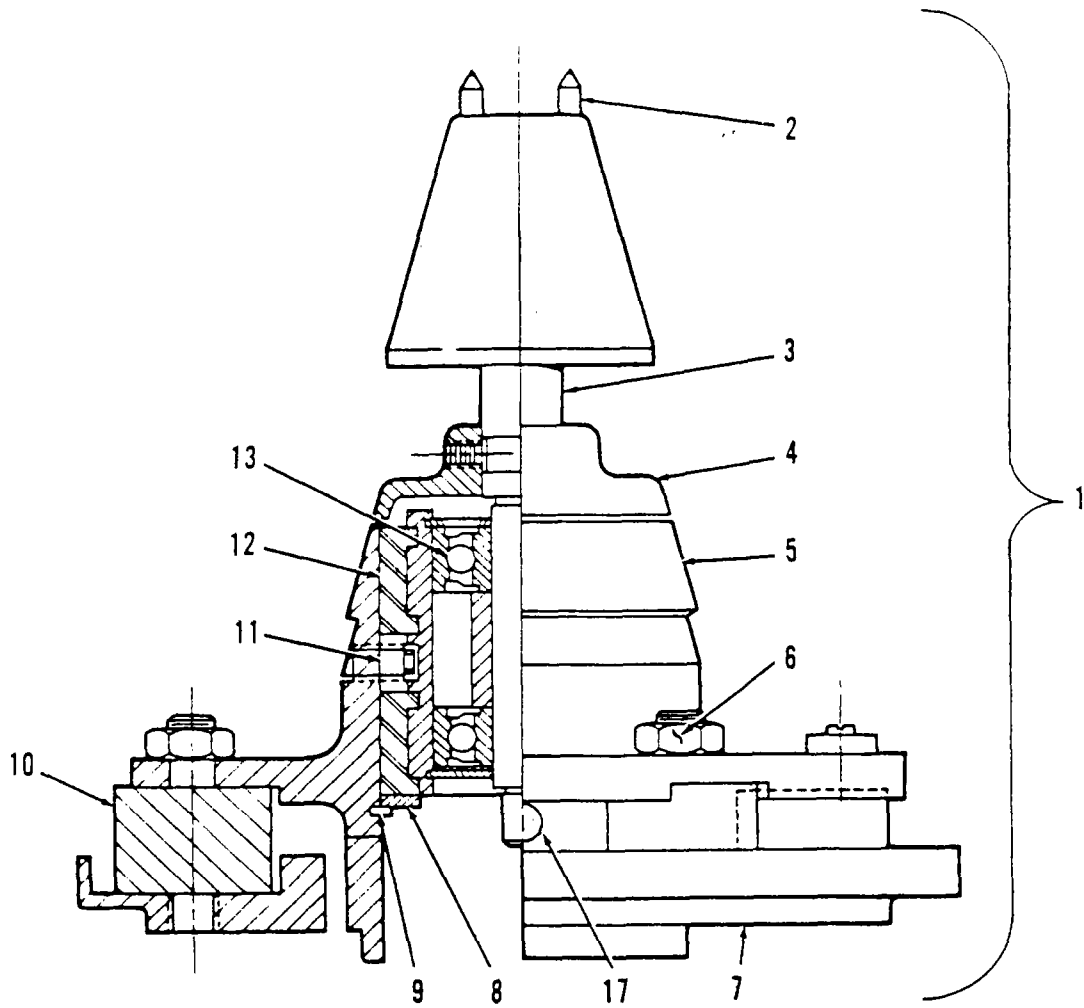

Figure 7-7. RC-5B PLUS Drive Assembly

Table 7-7. RC-5B PLUS Drive Assembly

Item No.	Description	Part No.
1	RC-5B PLUS Gyro Action Drive Assembly	12817
2	Pin, Tapered Spindle	204742
3	Spindle Assembly	12348
4	Slinger, Sealing	50578
5	Mounting Plate, Upper	50812
6	Nut, Hex, SST, UNC, 5/16-18	67273
7	Mounting Plate, Lower	50407
8	Washer, Support	50409
9	Retaining Ring	67270
10	Mount, Flex-Bolt	50408
11	Set Screw, Hex Socket, SST, UNC, #1/4-20 x 3/8 long	67272
12	Housing Assembly, Bearing	50405
13	Bearing Replacement Kit	12342
14	Imbalance Detector	50843
15	Screw, Pan Head, Slotted, SST, UNC, #2-56 x 1/4 long	63818
16	Insulator	67710
17	Plug, Access Hole	67341

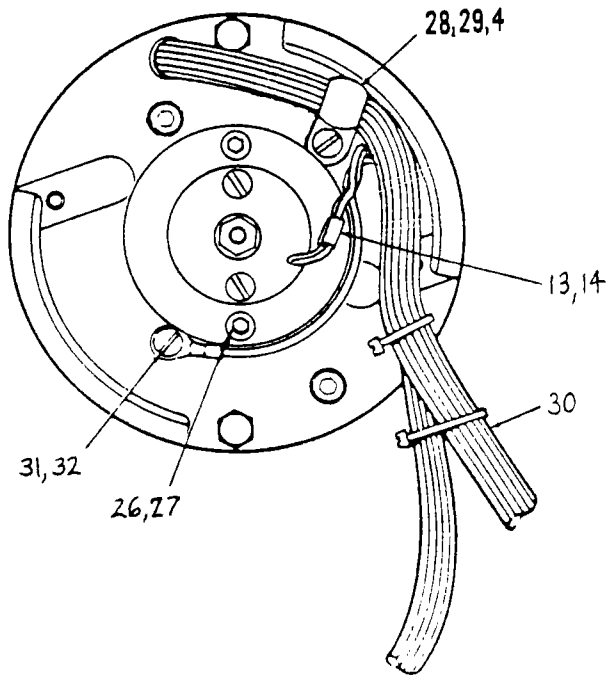
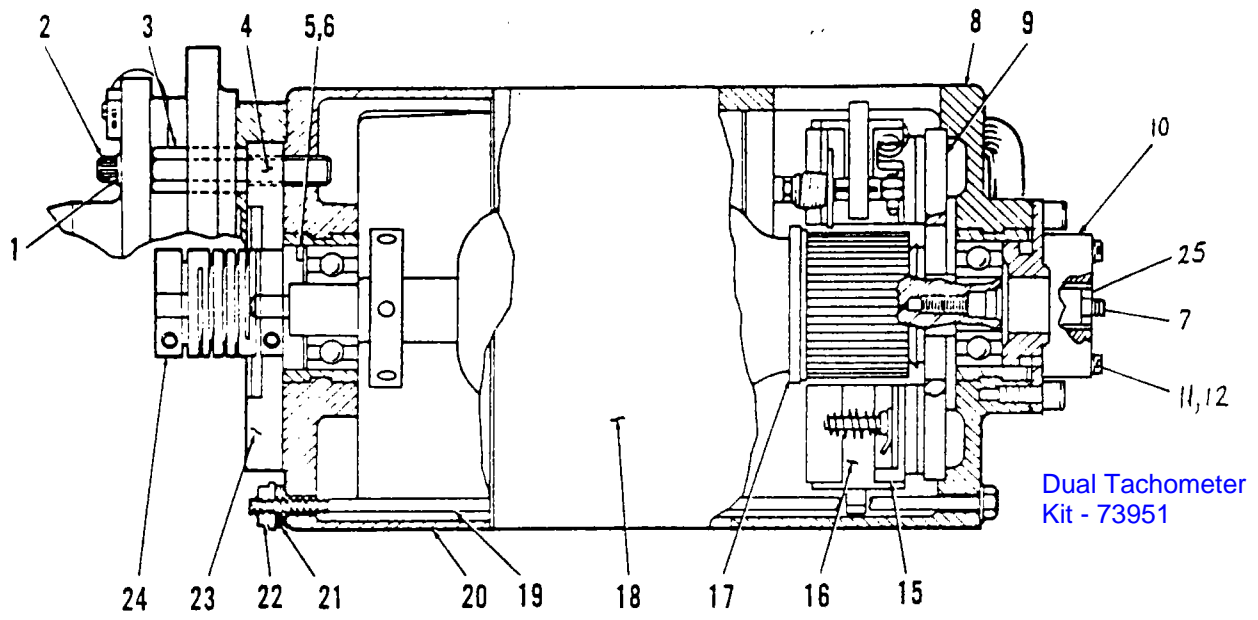

Figure 7-8. RC-5B PLUS Motor Assembly

Table 7-8. RC-5B PLUS Motor Assembly

Item No.	Description	Part No.
—	RC-5B PLUS Motor Assembly	74061
1	Split Lockwasher, #10, SST, 0.040 thick	63016
2	Cap Screw, Socket Head Hex, SST, UNF, #10-32 x 3/4 long	60568
3	Standoff, 7/16 Hex, Male 1/2-20 Female #10-32	50418
4	Adhesive, Sealant, Loctite, #222	65811
5	Washer, Spring, Wavy, 1.051 I.D. x 1.351 O.D. x 0.99 H	67281
6	Shim, 0.010 thick	20483
6	Shim, 0.020 thick	20509
6	Shim, 0.040 thick	20510
7	Adapter, Tachometer Generator	06042
8	End Bell, Lower, Motor	74142
9	Disc, Insulating, Motor	20478
10	Tachometer Generator	20524
11	Screw, Pan Head, SST, Slotted, Self-Lock, #5-40 x 3/4 long	61860
12	Lockwasher, Internal, SST, #5	61496
13	Contact, Electrical Connector, Male, 20-14	61864
14	Connector, Body, Plug, 1 Position	61940
15	Holder Assembly, Plate & Brush, RC-5B PLUS	74062
16	Brush, Commutator, 1-1/4 long x 0.990 W x 1/4 thick	66609
17	Armature Assembly includes	74051
	Armature	50419
	Slinger	74050
	Ball Bearing, Extra Quiet	90984
	Slinger	204672
	Wafer Insulation	50824
	Bearing Spacer	50088
18	Housing & Stator Assembly, Motor (Machining)	20612
19	Rod, Tie, Motor	20507
20	Bell, End, Upper, Motor	50421
21	Washer, Spring, Belleville, 0.19 I.D. x 0.375 O.D. x 0.03 H x 0.02 thick	61980
22	Nut, Flange, Low Carbon STL, Zinc Plated, UNC #10-24	91442
23	Plate, Preload	50416
24	Coupling Assembly	12345
25	Nut, Hex, Flexloc, Aluminum, #6-32	60554
26	Cap Screw, Socket Head, Hex, STL, Zinc Plated, #10-24 x 1/2 long	91443
27	Split Lockwasher, #10 x 0.040, SST	60346
28	Clamp, Cable, Plastic, 1/2 inch diameter	91492
29	Screw, Pan Head, Phillips, SST, UNC, #8-32 x 3/8 long	91420
30	Harness Assembly, Motor	74069
31	Screw, Pan Head, with Lockwasher, SST UNC, #10-24 x 1/4 long	91424
32	Lockwasher, #10 External Tooth, SST	67896

10

Dual Tachometer Kit

92312

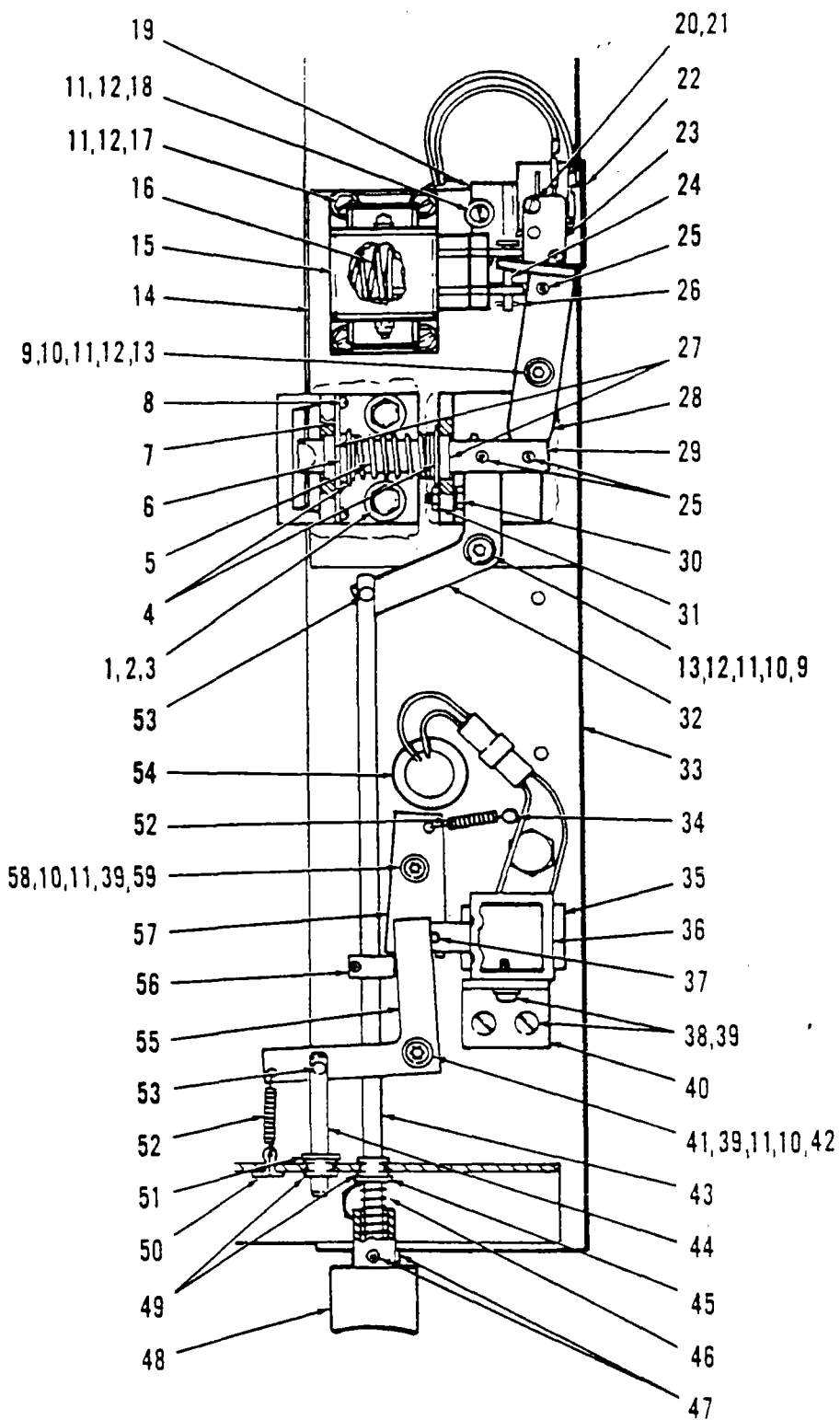

Figure 7-9. RC-5B PLUS Door Interlock Assembly (Part A)

Table 7-9. RC-5B PLUS Door Interlock Assembly (Part A)

Item No.	Description	Part No.
1	Flat Washer, STL, 5/16, 11/32 I.D. x 11/16 O.D. x 1/16 thick	60885
2	Split Lockwasher, 5/16, SST, 0.078 thick	63023
3	Screw, Hex Head, STL, 5/16-18 x 1-1/4 long	64747
4	Flat Washer, 0.515 I.D. x 0.875 O.D. x 0.016 thick, SST, Cad Pl	66341
5	Spring, Compression, 0.53 I.D. x 2.3 long, 0.038 Wire Diameter, SST	50076
6	Ring, Retaining, External, 1/2 inch Shaft Diameter	62503
7	Retainer, Bushing	50111
8	Screw, Pan Head, SST, Slotted, UNC, #4-40 x 3/16 long	62913
9	Support, Linkage, Interlock	50572
10	Flat Washer, Nylon, 0.39 I.D. x 0.625 O.D. x 0.031 thick	61889
11	Flat Washer, #10, SST, 13/64 I.D. x 7/16 O.D. x 0.031 thick	61652
12	Split Lockwasher, #10, SST, 0.040 thick	60346
13	Cap Screw, Socket Hex Head, SST, UNRF, #10-32 x 1-1/4 long	90340
14	Weldment Assembly, Door Interlock	50077
15	Solenoid, Pull Type, Modified	50872
16	Compression Spring	68745
17	Cap Screw, Socket Hex Head, STL, UNF, #10-32 x 1/2 long	64301
18	Screw, Pan Head, Slotted, SST, UNF, #10-32 x 3/8 long	61597
19	Microswitch Bracket Assembly	50887
20	Screw, Pan Head, Slotted, SST, UNC, #4-40 x 5/8 long	62396
21	Split Lockwasher, #4, SST, 0.020 thick	63004
22	Insulator, Fish Paper, 1-19/32 x 1 x 0.015 thick	62245
23	Microswitch, SPDP	66753
24	Pin, Clevis, 0.187 diameter x 0.75 inch long	68080
25	Pin, Spring, Spiral, 1/8 diameter x 5/8 long	63238
26	Pin, Hitch, 0.042 diameter x 31/32 long	67567
27	Bearing, Nylon, Flanged, 1/2 I.D. x 7/32 long	66314
28	Link, Solenoid	50870
29	Plunger, Door Interlock	50871
30	Screw, Hex Head, SST, Unslotted, UNC, #6-32 x 5/8 long	68746
31	Nut, Hex, SST, #6-32	60074
32	Link, Manual Release	50869
33	Door Interlock Support Plate	50776
34	Post, Spring, 0.188 x 1.50 long	68161
35	Tape, Insulating, 1 inch x 1-1/2 inch	67710
36	Solenoid Assembly	50803
37	Pin, Spring, Self Locking, 0.093 x 0.62	67904
38	Screw, Binding Head, SST, #10-32 x 5/16 long	60855
39	Split Lockwasher, SST, #10 x 0.040 thick	60346
40	Bracket, Solenoid	50501
41	Cap Screw, Socket Head, SST, 10-32 x 1-7/8 long	67906
42	Spacer, Round, 0.194 I.D. x 1/2 O.D. x 1-7/16 long	68160
43	Rod, Door, Manual Release	50881
44	Rod, Solenoid Release	50522
45	Flat Washer, 1/4, STL, Zinc Plated, 0.281 I.D. x 0.734 O.D. x 0.063 thick	91366

Table 7-9. RC-5B PLUS Door Interlock Assembly (Part A)

Item No.	Description	Part No.
46	Spring, Compression, 0.360 O.D. x 1.00 FL x 0.032 Wire	67899
47	Setscrew, Socket Head, Cup Point, STL, #10-32 x 3/16 long	64342
48	Button, Door Interlock	50689
49	Bearing, Nylon, Snap-in, Shaft Size 0.25 diameter	63985
50	Pin, Cotter, SST, 1/16 x 1/2 long	60315
51	Ring, Retaining, External, 1/4 shaft diameter	67903
52	Spring, External, 0.18 O.D. x 1.00 long x 0.018 Wire	68209
53	Pin, Cotter, Hairpin, SST, 0.092	66979
54	Bushing, Snap, 3/4 I.D., 1.0 Mounting Hole	68214
55	Arm, Solenoid Release	50612
56	Collar, Clamp Tite	68172
57	Link, Interlock	50502
58	Spacer, Round, 1/2 O.D. x 0.194 I.D. x 1-1/8 long	67900
59	Cap Screw, Socket Head, SST, #10-32 x 1-11/16 long	60580
—	Door Interlock Assembly (Items 1-32)	50868

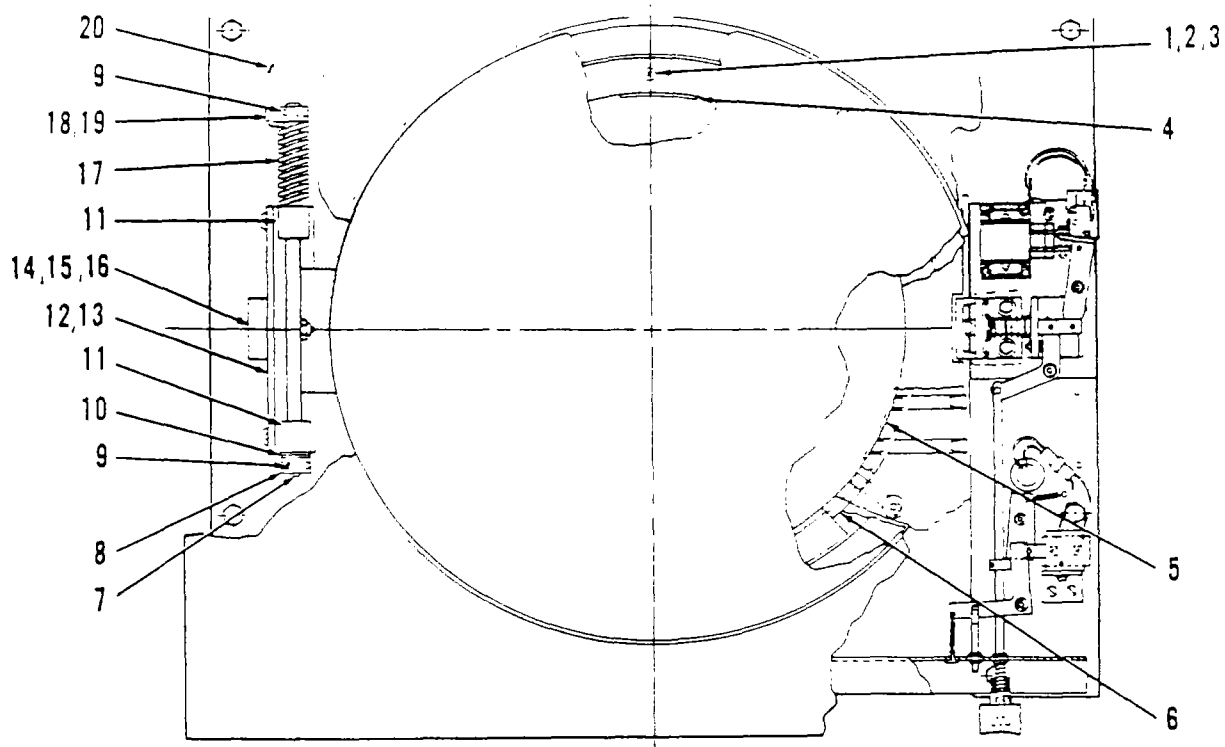

Figure 7-10. RC-5B PLUS Door Interlock Assembly (Part B)

Table 7-10. RC-5B PLUS Door Interlock Assembly (Part B)

Item No.	Description	Part No.
1	Screw, Flat Head, Phillips, Wood #10 x 1-3/4 long	65660
2	Seal Ring, Door, Lower	50079
3	Shroud	74059
4	Label, Rotation	62541
5	Stopper, KSB Outlet	20845
6	Lower Seal Ring	20006
7	Pin, Spring, Spiral 1/4 diameter x 1 long	63240
8	Stop, Door	50101
9	Pin, Spring, Spiral 3/16 diameter x 1 long	63239
10	Flat Washer, Nylon, 1/2 I.D. x 1 O.D. x 1/16 thick	66349
11	Block, Mounting, Shaft (Spring)	50102
12	Bracket, Mounting	50083
13	Shim	66183
14	Switch, Push Button, SPDT DPDT	91457 66383
15	Nut, Thin Hex, Brass, 3/8-32	66668
16	Washer, Internal Tooth, SST, 3/8, 0.388 I.D. x 0.687 O.D.	62033
17	Spring, Torsion, .55 I.D. x 2.8 long	50106
18	Setscrew, Slotted, Cup Point, 1/4-20 x 7/8 long	66743
19	Retainer Spring	50100
20	Plate, Support, Hinge	50080

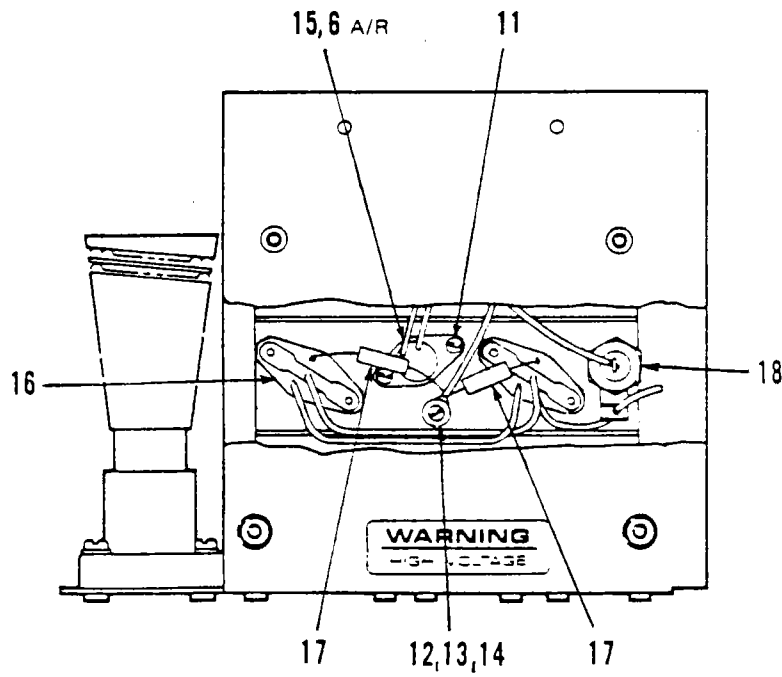
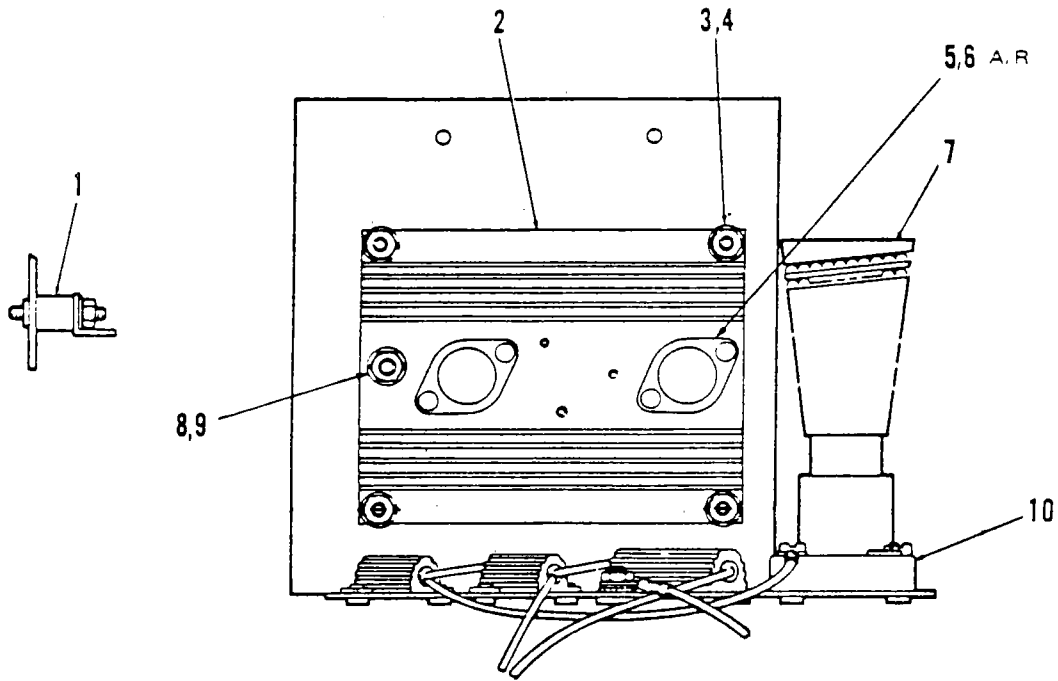

Figure 7-11. RC-5B PLUS Constant Current Brake Assembly

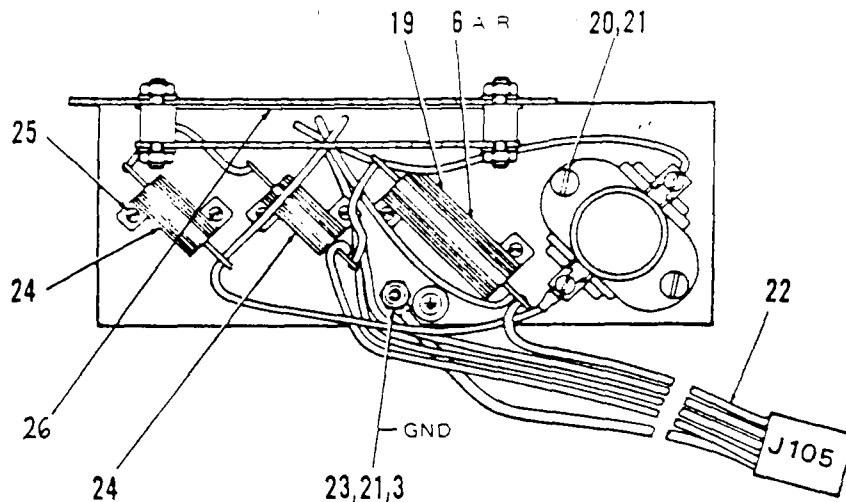

Figure 7-11. RC-5B PLUS Constant Current Brake Assembly (continued)

Table 7-11. RC-5B PLUS Constant Current Brake Assembly

Item No.	Description	Part No.
—	Constant Current Brake Assembly	50687
1	Standoff, Male, #10-32, Delrin, Norelcom #51130-R-D-0.500 with 0.375 long THRD	68158
2	Heatsink	50770
3	Nut, Hex, SST #10-32	60012
4	Flat Washer, SST, #10, 13/64 I.D. x 7/16 O.D. x 0.031 thick	61652
5	Transistor, Power NPN, 2N3055	920505
6	Thermal Compound, 8 oz jar, Wakefield #120-8	N/A
7	Resistor, Braking, 2.7 Ohms, 1000 W	61487
8	Nut, Hex, SST, #1/4-20	61141
9	Split Lockwasher, #1/4, SST, 0.047 thick	63019
10	Receptacle, Braking, Resistor, 660 W, 250 V	60406
11	Screw, Pan Head, Slotted, UNC, #4-40 x 3/8 long	62395
12	Screw, Nylon, Pan Head, #6-32 x 1/2 long	67606
13	Flat Washer, Nylon, #10 x 1/8 thick	67383
14	Flat Washer, SST, 0.169 I.D. x 0.304 O.D. x 0.032 thick	63085
15	Thermostat	68173
16	Mounting Kit	65580
17	Resistor, Wirewound, 0.010 Ohms, 2 W	68171
18	Rectifier, Silicon, 100 V, 1N249C	68563
19	Resistor, Wirewound, 0.5 Ohms, 30 W	68170
20	Screw, Pan Head, Slotted, SST, UNF, #10-32 x 3/4 long	61118
21	Split Lockwasher, #10 SST, 0.040 thick	63016
22	Harness Assembly, Constant Current Brake	50774
23	Lockwasher, External Tooth, #10, SST	67896
24	Resistor, Wirewound, 0.5 Ohms, 25 W	68169
25	Screw, Pan Head, Slotted, SST, UNC, #4-40 x 3/16 long	62913
26	Insulation, Fishpaper	50879
27	Screw, Pan Head, Phillips, SST, UNF, #10-32 x 1/2 long	65768

Section 8: PREVENTIVE MAINTENANCE

This section includes the preventive maintenance procedures necessary to keep the RC-5B PLUS centrifuge operating properly.

THIS SECTION IS NOT YET AVAILABLE



RC5B/5B PLUS



Preventative Maintenance Checklist

Account Name:		Instrument Model:	
Account Address:		Serial Number:	
Report Number:		Date:	

Rotor Inspection

- Check for corrosion or excessive wear
- Lubricate buckets and trunnions
- Inspect Rotor locking stud

Pre-Run Checks

- Ground Continuity
- Condenser fins/Air Filter cleaned
- Rotor Chamber (defrost)
- Door interlock and latch
- Door seal
- Line Voltage _____VAC
- Door spring functional
- Ambient conditions

Electronic Checks

- Power light & door light (zero speed) on
- Compressor current _____ amps
- Torque trimmer set
- Maximum speed
- Motor cooling fan (5B+ only)
- Speed Control calibration
- Set Temperature calibration
- Compressor cycle time
- Timer function
- Overtemperature
- Brake function
- Overspeed

Mechanical

- Lubricate door latch
- Interlock Microswitch Adjustment
- Refrigeration leaks
- Door screws secure
- Replace heat sink standoffs on brake assembly

Motor and Gyro

- Gyro bearings
- Gyro bushings
- Lower coupling
- Replace motor brushes
- Commutator
- Tachometer
- Replace motor hardware
- Motor ground continuity
- Replace gyro seal and cushion
- Brush warning (brush motor only)
- Inspect and replace tapered spindle pins

Imbalance

- Centrifuge stable and level
- Centrifuge shuts off with proper weight

Comments:

S.R. Signature _____

Date:

Section 9: REPAIR & REPLACEMENT

This section of the service manual includes the procedures necessary to repair or replace parts of the centrifuge. A complete listing of replaceable parts can be found in Section 7, Illustrated Parts.

THIS SECTION IS NOT YET AVAILABLE

Section 10: SYSTEM DESCRIPTIONS

This section of the service manual provides an overall description of the RC-5B PLUS centrifuge operating systems and provides greater detail about the refrigeration system, drive system, electronic controls, and interlocks. For functional descriptions of the centrifuge systems, such as brake control, acceleration, temperature control, refer to Section 11, Troubleshooting.

THIS SECTION IS NOT YET AVAILABLE

Section 11: TROUBLESHOOTING

This section provides information that will assist you in troubleshooting centrifuge malfunctions. It also includes system diagnostics and the emergency sample recovery procedure.

11-1. Emergency Sample Recovery



WARNING

When the main power shuts off, the brake will not operate. Wait until the rotor stops (approximately 15 minutes) before using the mechanical override. Reaching into the rotor chamber before the rotor has stopped spinning could cause personal injury.

If the main power shuts off because of a power failure or a system malfunction while the rotor is spinning, the RC-5B PLUS chamber door will not unlatch. A mechanical override is provided to allow sample recovery in the case of an emergency. This procedure should never be used routinely and is intended for emergency sample recovery only.

The door latch override button is recessed beneath the top deck to the left of the door button (see figure 11-1). To open the chamber door, push the door latch override button with a pencil or similar object and—at the same time—push the door button. The chamber door will open.

NOTE The chamber door will not open if the door latch override button and door button are not pushed at the same time.

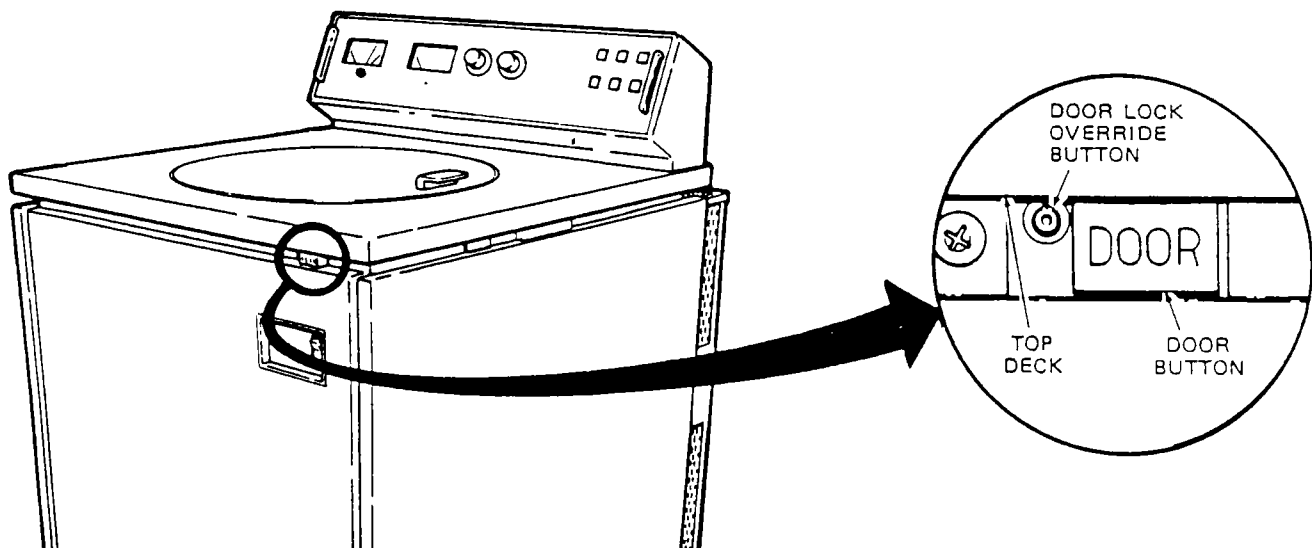

Figure 11-1. Door Latch Override Button Location

11-2. General Troubleshooting

Information Not Yet Available

EQUIPMENT SERVICE & SUPPORT		INFORMATION SERVICE BULLETIN	
EQUIPMENT: RC-5B+ & RC-5C+	BULLETIN NO.: RC5/5B-02/RC5C-01	DATE: 10/01/94	DISTRIBUTION LIST: L4226 (018)

EVAPORATOR LINER ASSEMBLY PART NUMBER

PURPOSE

To notify the Field Service Organization of the new part number for the RC-5B+ and RC-5C+ evaporator liner assembly.

EFFECTIVITY

All RC-5B+/5C+ instruments with HP-62 refrigerant.

INFORMATION

Since the introduction of the new HP-62 refrigerant in the RC5B+/5C+, there have been some changes to the evaporator liner refrigeration connections and how the liner is mounted in the centrifuge.

If the compressor assembly has the new HP-62 label, it will require the new liner.

The part number for the evaporator liner is P/N 56216. This part number is for the liner only. A part number for the kit assembly will be assigned at a later date.

AUTHOR

Larry Farmer
Service Technical Support
Phone: (302) 451-5830



EQUIPMENT SERVICE & SUPPORT	INFORMATION SERVICE BULLETIN		
EQUIPMENT: RC-5B+/RC-5C+	BULLETIN NO.: RC5/5B-03/RC5C-06	DATE: 12/30/95	DISTRIBUTION LIST: L4226 (018) L4359

FRONT PANEL DECAL PART NUMBERS

PURPOSE

To notify the Field Service Organization of the front panel decal part numbers for the RC-5B+ and RC-5C+ instruments.

EFFECTIVITY

All RC-5B+ and RC-5C+ instruments

INFORMATION

The Preliminary Service Manual (issued June 1993) for the RC-5B+ and RC-5C+ does not show the front panel decal. Item #25 in Table 7.2 on page 7.5 for RC-5B+ and Item #25 in Table 8.2 on page 8.4 for RC-5C+ shows the front panel assembly (P/N 74112), but this is the basic front panel. It is painted and has bushing inserts and foam insulation installed on it. However, the decal identifying the particular model is not included. This decal is added on the manufacturing floor, since this front panel can be used on both the RC-5B+ and RC-5C+ instruments.

Make a note beside Item #25 in Table 7.2 and Item #25 in Table 8.2 that the RC-5B+ decal is not included with the front panel assembly (P/N 74112).

The part number for the RC-5B+ decal is 74042. Create Item #46 in Table 7.2 for the RC-5B+ front panel decal.

The part number for the RC-5C+ decal is 74524. Create Item #46 in Table 8.2 for the RC-5C+ front panel decal.

AUTHOR

Larry Farmer
Sr. Equipment Specialist
Phone (203) 270-2271



SORVALL SERVICE & SUPPORT		INFORMATION SERVICE BULLETIN	
EQUIPMENT RC-5B PLUS, RC-5C PLUS	BULLETIN RC5/5B-05, RC5C-09	ISSUE DATE 03/31/97	DISTRIBUTION LIST WORLDWIDE

PART NUMBER FOR CONSOLIDATED MOTOR KIT FOR SUPERSPEEDS

PURPOSE

To inform the Field Service Organization of part number for new consolidated motor kit to be used in RC-5B PLUS and RC-5C PLUS instruments.

EFFECTIVITY

Immediate

INFORMATION

A new consolidated motor, Part Number 74510, has been designed for use in either the RC-5B PLUS or the RC-5C PLUS. This will help to reduce spare parts inventory.

Motor Kit PN 74510 contains:

- | | | |
|---|----------|------------------------|
| 1 | PN 74512 | Harness, Adapter |
| 1 | PN 74511 | Motor Assembly, 5B/5C+ |
| 1 | PN 74513 | Instructions, Motor |
| 1 | PN 24188 | Motor Shipping Carton |
| 1 | PN 24190 | Susrap |

Use your current stock of RC-5B PLUS motors (PN 74061) and RC- 5C PLUS motors (PN 74528). When our supply of those motors has been depleted, you should order the interchangeable motor kit (PN74510).

NOTE: The new consolidated motor does not include tachometer components as PN 74061 and PN 74528 had. Therefore, when you determine that you need a new motor kit (PN 74510), then you will have to order separately any tachometer parts which need replacement.

AUTHOR L. FARMER	PHONE (203) 270-2094	REVIEWED BY <i>Burt Cigley</i>	REVIEW DATE 3/31/97
----------------------------	--------------------------------	--	-------------------------------

SORVALL SERVICE & SUPPORT		INFORMATION SERVICE BULLETIN	
EQUIPMENT RC-5B, RC-5B PLUS, RC-5C, RC-5C PLUS	BULLETIN RC5/5B-06, RC5C-10	ISSUE DATE 03/31/97	DISTRIBUTION LIST WORLDWIDE

CHANGE OF MATERIAL IN QUIET DRIVE COUPLING

PURPOSE

To inform the Field Service Organization of a change of material in the Quiet Drive Couplings.

EFFECTIVITY

Immediate

INFORMATION

Stainless steel drive couplings have replaced the aluminum drive couplings in order to prevent breakage of the couplings. Although the new material has increased the noise level somewhat, it is still within acceptable limits. The new drive couplings are in all new production of RC-5B PLUS and RC-5C PLUS instruments.

Our supply of Drive Coupling Kits (PN 12345) with aluminum drive couplings will be used until depletion. As new kits are built, the stainless steel drive couplings will be incorporated.

The stainless steel couplings were put into production at the following serial number breaks:

RC-5C PLUS	9700306
RC-5B PLUS	9700356

AUTHOR L. FARMER	PHONE (203) 270-2094	REVIEWED BY <i>Bent Coffey</i>	REVIEW DATE 3/31/97
---------------------	-------------------------	-----------------------------------	------------------------

SORVALL SERVICE & SUPPORT			ACTION SERVICE BULLETIN		
EQUIPMENT RC-5B PLUS		BULLETIN RC5/5B-07	ISSUE DATE 03/31/97	DISTRIBUTION LIST WORLDWIDE	
MOD CODE EBAA	CLASS AD	BREAK-IN SN 9700001		CHARGE CODE Warranty	

RE-ROUTING MAIN WIRE HARNESS

PURPOSE

To inform the Field Service Organization of a potential problem with the routing of the main wire harness and the need to re-route it on your next visit.

EFFECTIVITY

All RC-5B PLUS instruments manufactured prior to January 1, 1997 (any SN below 9700001)

INFORMATION

Wire-chafing is occurring at the condenser assembly due to the 90 degree bend in the wiring and the weight of the harness on the upper right hand corner of the condenser. A mod is required which should be done during your next Preventive Maintenance visit or service call.

During current production, two adhesive cable clamps are now used to relieve the weight of the harness, one clamp located on the condenser, the other on the Motor Cool Fan Bracket. The field mod is to be done by placing a piece of foam over the sharp corner or using a cable tie on the harness to relieve the weight of the harness.

Attached is a sample FSR and a diagram showing before and after views of the problem area.

Attachments

AUTHOR L. FARMER	PHONE 203-270-2094	REVIEWED BY <i>Burt Cough</i>	REVIEW DATE 3/31/97
---------------------	-----------------------	----------------------------------	------------------------



(REF-NO.)
 LABOR: WT/CONT/BILL
 PARTS: WTY/CONT/BILL

Field Service Report

PG 1 OF 1
 TURN-OVER _____
 CLOSE _____

ACCOUNT: UNIV. OF KENTUCKY PHONE: 606-233-6502
 ADDRESS: NEPHROLOGY MN569 CONTACT NAME: DR. A.B. SMITH
 CITY: LEXINGTON STATE: KY ZIP: 40536-0084
 MODEL: RC5B+ SERIAL NO: 9401997
 CALL DESC: _____

ADMINISTRATION	WORK DATE	FSE NO.	WORK CODE	HOURS	WORK CODE DESCRIPTION	
	1	970424	17797	MD	1.0	EBAA
	2	970424	17797	TT	.5	
	3					
	4					
	5					
	6					
	7					

COMMENTS PERFORMED MODIFICATION EBAA ON RC5B+. NO PROBLEMS ENCOUNTERED

BILLING & PARTS	FSE NO.	LINE CODE	QTY.	PART NUMBER	PART/CHARGE DESCRIPTION	UNIT PRICE	LINE TOTAL	BILL TO
	1							
	2							
	3							
	4							
	5							
	6							
	7							
	8							
	9							
10								

(THIS IS NOT AN INVOICE.)

TOTAL: _____

CROSS-CHG. NO. _____ CUSTOMER P.O.: _____
 FSE NAME: JOHN A. DOE CUSTOMER'S NAME: DR. A.B. SMITH
 DATE: APRIL 24, 1997 CUSTOMER'S SIGNATURE: Albert B. Smith

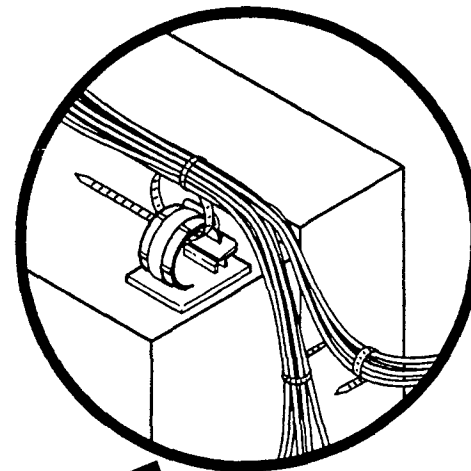
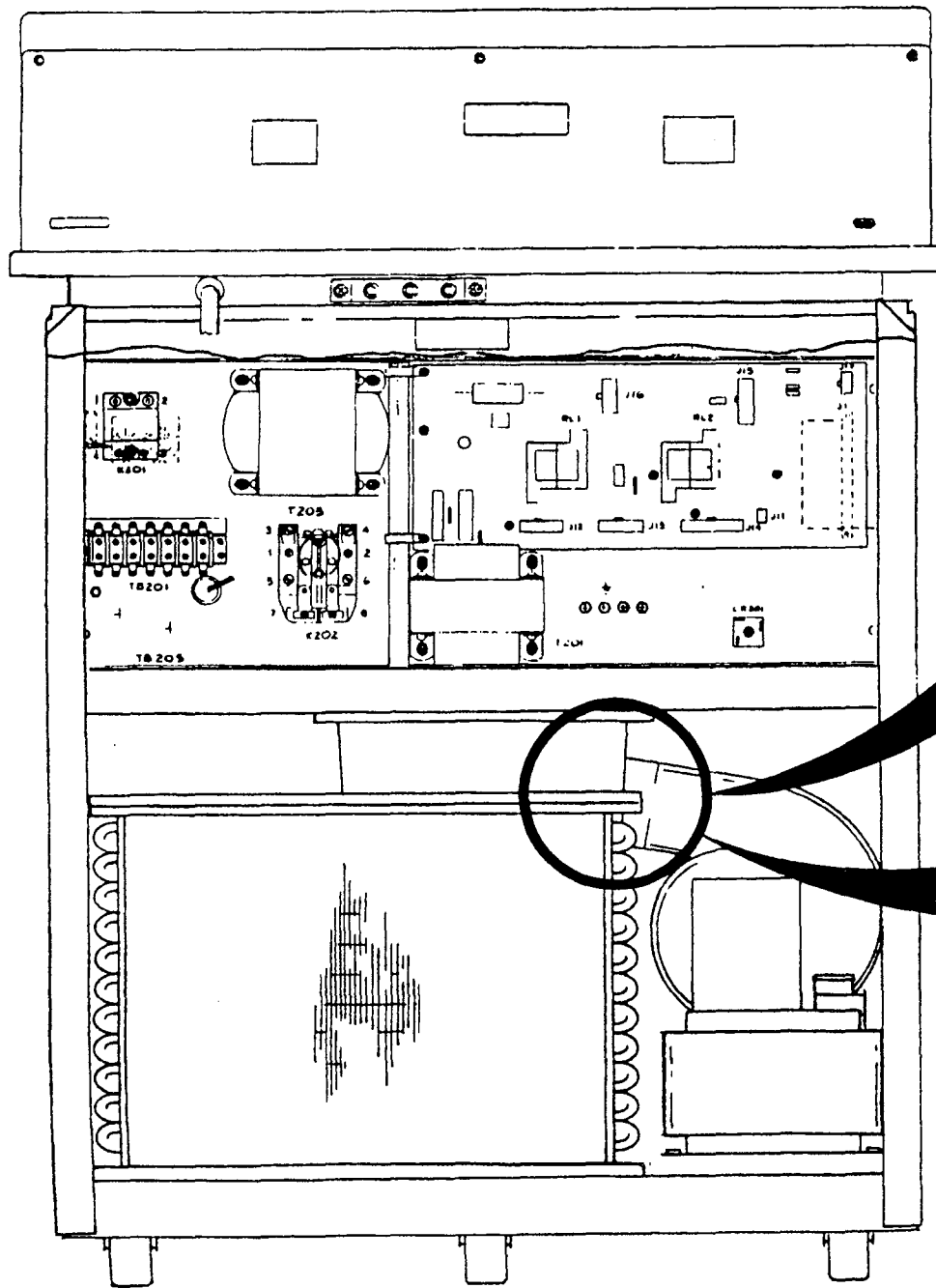

AFTER

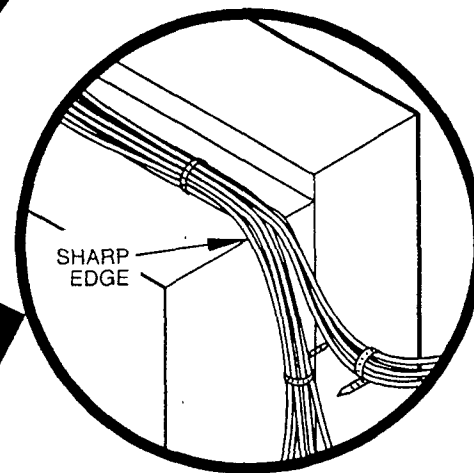

BEFORE

SORVALL SERVICE & SUPPORT		INFORMATION SERVICE BULLETIN	
EQUIPMENT RC-5B PLUS	BULLETIN RC5/5B-08	ISSUE DATE 03/31/97	DISTRIBUTION LIST WORLDWIDE

PART NUMBER FOR WHITE LED

PURPOSE

To inform the Field Service Organization of part number for white LED used on RC-5B PLUS Panel Assembly.

EFFECTIVITY

Immediate

INFORMATION

The part number for the white LED used in the assemblies listed below is PN 91661. This LED is an SPL part and is currently stocked at WPC.

Part Description	PN	Use
Indicator, Lighted Assembly	74122	Brushes, Door and Imbalance
Switch, Push Button	74123	Start
Indicator, Lighted Assembly	74124	Power
Switch, Push Button	74125	Brake

AUTHOR L. FARMER	PHONE (203) 270-2094	REVIEWED BY <i>But Clegg</i>	REVIEW DATE 3/31/97
---------------------	-------------------------	---------------------------------	------------------------

EQUIPMENT SERVICE & SUPPORT		INFORMATION SERVICE BULLETIN	
EQUIPMENT: RC-5C/5CPlus	BULLETIN NO.: RC5C-04	DATE: 4/14/95	DISTRIBUTION LIST: L4226 (018)

SWITCH & INDICATOR SWITCH PART NUMBERS

PURPOSE

To notify the Field Service Organization of part numbers for the individual switches found on the Switch & Indicator PC Board (P/N 50685).

EFFECTIVITY

All RC-5C/5CPlus instruments.

INFORMATION

The following part numbers are for the individual switches found on the Switch and Indicator PC Board (P/N 50685). These are SPL part numbers and are in stock at WPC. Please note that these part numbers are in your RC-5C Service Manual on Page 5-92 in Table 5-6, and in the RC-5C+ Service Manual on Page 8-9 in Table 8-5, Item #8.

<u>Switch</u>	<u>Function</u>	<u>Type</u>	<u>DuPont P/N</u>	<u>Mfg P/N</u>	<u>Tab Color</u>
S1	BRAKE/OFF	Toggle	67183	C&K U11-J2-V3-Q-E	Black
S2	HOLD/OFF	Toggle	67183	C&K U11-J2-V3-Q-E	Black
S3	ARC/OFF	Toggle	67183	C&K U11-J2-V3-Q-E	Black
S4	TIMED/w ² DT	Toggle	67183	C&K U11-J2-V3-Q-E	Black
S5	START	Momen	68048	C&K U18-J2-V3-Q-E	White
S6	STOP	Momen	68047	C&K U18-J2-V3-Q-E	Red
S7	RPM/RCF	Momen	68049	C&K U18-J2-V3-Q-E	Black

AUTHOR

John Braun
Customer Support Center
Phone: (302) 451-5699



EQUIPMENT SERVICE & SUPPORT	INFORMATION SERVICE BULLETIN		
EQUIPMENT: RC-3C+/RC-5C+	BULLETIN NO.: RC3C-10/RC5C-05	DATE: 12/30/95	DISTRIBUTION LIST: L4226 (018) L4359

KEY SWITCH ASSEMBLY

PURPOSE

To notify the Field Service Organization of a part change in the RC-3C+ and RC-5C+ Key Switch Assembly, P/N 50798.

EFFECTIVITY

All RC-3C+ and RC-5C+ Centrifuges

INFORMATION

The Key Switch Assembly (P/N 50798) used in the RC-3C+/5C+ has been changed to a new component, but the part number will remain the same.

The new Key Switch Assembly used in the RC-3C+/5C+ comes with a key, but if the customer should misplace the key, 91499 is the replacement key part number.

NOTE: The Key Switch Assembly (P/N 50798) was also used in the RC-3C, RC-5C and OTD-2 centrifuges. The new key switch is backwards compatible in these centrifuges, but the old key (P/N 65919) will not work in the new key switch. The old style key (P/N 65919) will be stocked at WPC. Since the key switch does not normally fail, just the key will get lost.

The best way to remember or to determine which is the correct key for part number 50798 is that all RC-3C+ and RC-5C+ will use key P/N 91499 and all RC-3C, RC-5C and OTD-2 will use key P/N 65919.

AUTHOR

Larry Farmer
Sr. Instrument Specialist
Phone (203) 270-2271



SORVALL SERVICE & SUPPORT		INFORMATION SERVICE BULLETIN	
EQUIPMENT RC-3C PLUS, RC-5C PLUS, RC3BP™	BULLETIN RC3C-12, RC5C-08, RC3BP-02	ISSUE DATE 03/31/97	DISTRIBUTION LIST WORLDWIDE

**PART NUMBER FOR REPLACEMENT KEY
(Reissue)**

PURPOSE

To inform the Field Service Organization of part number for replacement key in RC-3C Plus, RC-5C PLUS and RC3BP™.

EFFECTIVITY

Immediate

INFORMATION

All RC-3C PLUS and RC-5C PLUS instruments are produced with a new Key Switch Assembly, PN 50798. This assembly comes with a key. If the customer requires an extra key or a replacement key, the part number is 91499.

The RC3BP™ has a new Key Switch Assembly, PN 56317 which also uses the new replacement key PN 91499.

Note: A Key Switch Assembly, PN 50798, was used in the RC-3C, RC-5C and OTD-2 centrifuges. The key used in the older style switch assembly was PN 65919. If the Key Switch Assembly needs to be replaced in the RC-3C, RC-5C or OTD-2 instrument, you must order the new Key Switch Assembly PN 50798 and inform the customer that his old key will not work in the new Key Switch.

Both keys will be stocked at WPC:

65919	RC-3C, RC-5C and OTD-2
91499	RC-3C PLUS, RC-5C PLUS, RC3BP™

AUTHOR L. FARMER	PHONE (203) 270-2094	REVIEWED BY <i>Burt Cough</i>	REVIEW DATE 3/31/97
---------------------	-------------------------	----------------------------------	------------------------

DECONTAMINATION CERTIFICATE

Instructions on the reverse of this card must be completed before field service or the return of the instrument or part to the Sorvall service facility.

NAME _____ DEPARTMENT _____
INSTITUTION _____ ADDRESS _____
CITY _____ STATE _____ ZIP _____
INSTRUMENT _____ SERIAL NUMBER _____
ROTOR _____ SERIAL NUMBER _____
PART _____ PART NUMBER _____
CONTAMINATE USED _____
DECONTAMINATION CERTIFIED BY _____
DATE DECONTAMINATED _____

DECONTAMINATION CERTIFICATE

Instructions on the reverse of this card must be completed before field service or the return of the instrument or part to the Sorvall service facility.

NAME _____ DEPARTMENT _____
INSTITUTION _____ ADDRESS _____
CITY _____ STATE _____ ZIP _____
INSTRUMENT _____ SERIAL NUMBER _____
ROTOR _____ SERIAL NUMBER _____
PART _____ PART NUMBER _____
CONTAMINATE USED _____
DECONTAMINATION CERTIFIED BY _____
DATE DECONTAMINATED _____

DECONTAMINATION CERTIFICATE

Instructions on the reverse of this card must be completed before field service or the return of the instrument or part to the Sorvall service facility.

NAME _____ DEPARTMENT _____
INSTITUTION _____ ADDRESS _____
CITY _____ STATE _____ ZIP _____
INSTRUMENT _____ SERIAL NUMBER _____
ROTOR _____ SERIAL NUMBER _____
PART _____ PART NUMBER _____
CONTAMINATE USED _____
DECONTAMINATION CERTIFIED BY _____
DATE DECONTAMINATED _____

INSTRUCTIONS

When an instrument that has been used with radioactive or pathogenic material requires servicing by Sorvall personnel either at the customer's laboratory or at Sorvall facilities, the following procedure must be complied with to insure safety of our personnel:

1. The instrument or part to be serviced shall be cleaned of all blood and other encrusted material and decontaminated prior to servicing by our representative. No radioactivity shall be detectable by survey equipment.
2. A Decontamination Information Certificate shall be completed and attached to the instrument or part.

If an instrument or part to be serviced does not have a Decontamination Information Certificate attached to it, and, in our opinion, the instrument or part presents a potential radioactive or biological hazard, our representative will not service the equipment until proper decontamination and certification has been completed. If an instrument is received at our

Service facilities and, in our opinion, is a radioactive or biological hazard, the sender will be contacted for instructions as to disposition of the equipment. Disposition costs will be borne by the sender.

Decontamination Information Certificates are included with these Operation Instructions. Additional certificates are available from your local technical or customer service representative. In the event these certificates are not available, a written statement certifying that the instrument or part has been properly decontaminated and outlining the procedures used will be acceptable.

NOTE

Service representatives will indicate on a Customer Service Repair Report if decontamination was required, and if so, what the contaminate was and what procedure was used. If no decontamination was required, it should be so stated.

INSTRUCTIONS

When an instrument that has been used with radioactive or pathogenic material requires servicing by Sorvall personnel either at the customer's laboratory or at Sorvall facilities, the following procedure must be complied with to insure safety of our personnel:

1. The instrument or part to be serviced shall be cleaned of all blood and other encrusted material and decontaminated prior to servicing by our representative. No radioactivity shall be detectable by survey equipment.
2. A Decontamination Information Certificate shall be completed and attached to the instrument or part.

If an instrument or part to be serviced does not have a Decontamination Information Certificate attached to it, and, in our opinion, the instrument or part presents a potential radioactive or biological hazard, our representative will not service the equipment until proper decontamination and certification has been completed. If an instrument is received at our

Service facilities and, in our opinion, is a radioactive or biological hazard, the sender will be contacted for instructions as to disposition of the equipment. Disposition costs will be borne by the sender.

Decontamination Information Certificates are included with these Operation Instructions. Additional certificates are available from your local technical or customer service representative. In the event these certificates are not available, a written statement certifying that the instrument or part has been properly decontaminated and outlining the procedures used will be acceptable.

NOTE

Service representatives will indicate on a Customer Service Repair Report if decontamination was required, and if so, what the contaminate was and what procedure was used. If no decontamination was required, it should be so stated.

INSTRUCTIONS

When an instrument that has been used with radioactive or pathogenic material requires servicing by Sorvall personnel either at the customer's laboratory or at Sorvall facilities, the following procedure must be complied with to insure safety of our personnel:

1. The instrument or part to be serviced shall be cleaned of all blood and other encrusted material and decontaminated prior to servicing by our representative. No radioactivity shall be detectable by survey equipment.
2. A Decontamination Information Certificate shall be completed and attached to the instrument or part.

If an instrument or part to be serviced does not have a Decontamination Information Certificate attached to it, and, in our opinion, the instrument or part presents a potential radioactive or biological hazard, our representative will not service the equipment until proper decontamination and certification has been completed. If an instrument is received at our

Service facilities and, in our opinion, is a radioactive or biological hazard, the sender will be contacted for instructions as to disposition of the equipment. Disposition costs will be borne by the sender.

Decontamination Information Certificates are included with these Operation Instructions. Additional certificates are available from your local technical or customer service representative. In the event these certificates are not available, a written statement certifying that the instrument or part has been properly decontaminated and outlining the procedures used will be acceptable.

NOTE

Service representatives will indicate on a Customer Service Repair Report if decontamination was required, and if so, what the contaminate was and what procedure was used. If no decontamination was required, it should be so stated.

For Ordering Information or to place an Order,
contact:

SORVALL CUSTOMER SERVICE
31 Pecks Lane
Newtown, CT 06470-2337
FAX: (203) 270-2166
(203) 270-2210

In the United States,
to place an Order, or to obtain
more information, call **TOLL FREE:**

1-800-522-SPIN
(1-800-522-7746)

For Product, Applications, Technical or
Service Information, contact:

SORVALL CUSTOMER CARE GROUP
31 Pecks Lane
Newtown, CT 06470-2337
FAX: (203) 270-2115

UNITED KINGDOM:

SORVALL (UK) Limited
International Centre
Boulton Road, Stevenage
Hertfordshire SG1 4QX
Telephone: (01438) 342911
FAX: (01438) 342915

ITALY:

SORVALL (Italiana) Srl
Via A. Volta N. 16
20093 Cologno Monzese (MI)
Telefono: 02/25302372
FAX: 02/2540526

**Other EUROPE, AFRICA,
or MIDDLE EAST:**

SORVALL International Sales
International Centre
Boulton Road, Stevenage
Hertfordshire SG1 4QX
UNITED KINGDOM
Telephone: 44 (1438) 342900
FAX: 44 (1438) 342925

Federal Republic of GERMANY:

SORVALL (Deutschland) GmbH
DuPont Strasse 1
61352 Bad Homburg v.d.H.
Telefon: 6172/87-2544
FAX: 6172/87-2547

People's Republic of CHINA

BEIJING:

SORVALL
Room N1203, Jing Bao Garden
183 An Ding Men Wai St.
Beijing 100011, P.R. China
Telephone: (010) 6426-2609
(010) 6425-6140
FAX: (010) 6426-2765

*Or contact a local representative
for **SORVALL®** products.*

FRANCE:

SORVALL (France) SA
LP 912
LES CONQUERANTS
1 avenue de l'Atlantique
Les Ulis
91976 COURTABOEUF Cedex
Téléphone: 01 69 18 77 77
FAX: 01 60 92 00 34

SHANGHAI:

SORVALL
Room 704, Aviation Building
45 Cao Xi Bei Road
Shanghai 200030, P.R. China
Telephone: (021) 6427-8768
FAX: (021) 6427-8767

**Other countries, including
CANADA, LATIN AMERICA,
ASIA PACIFIC, or JAPAN:**

SORVALL International Sales
31 Pecks Lane
Newtown, CT 06470-2337
U.S.A.
Telephone: (203) 270-2080
FAX: (203) 270-2210
(203) 270-2500

*Or contact a local representative
for **SORVALL®** products.*

SORVALL®
C E N T R I F U G E S